



Storytelling in design

The power of stories & how they can be used for multi-device design

by Anna Dahlström | @annadahlstrom

Funkas Tillgänglighetsdagarna, Stockholm 13 April 2016



Once upon a time
in a city called 'Lund'...

A photograph of two cardboard robot figures, known as Daruma, resting on a patterned blanket. The robots are made of brown cardboard and have simple black dot eyes and a triangular mouth. One robot is larger and positioned behind the other. The background is a warm, golden light, possibly from a lamp, creating a soft glow. The blanket has a pattern of green and yellow floral or abstract shapes. A blue text box is overlaid on the left side of the image.

There where
plenty of story times

A person with large, white, feathered wings is seen from behind, wearing dark blue overalls. They are standing in a field at sunset. A small brown bird is flying in the air to the right. The background is a soft, golden glow from the setting sun.

We travelled
through those stories



“We are as a species addicted to stories.”

- *The Storytelling Animal* by Jonathan Gottschall

Storytelling

Storytelling

Storytelling

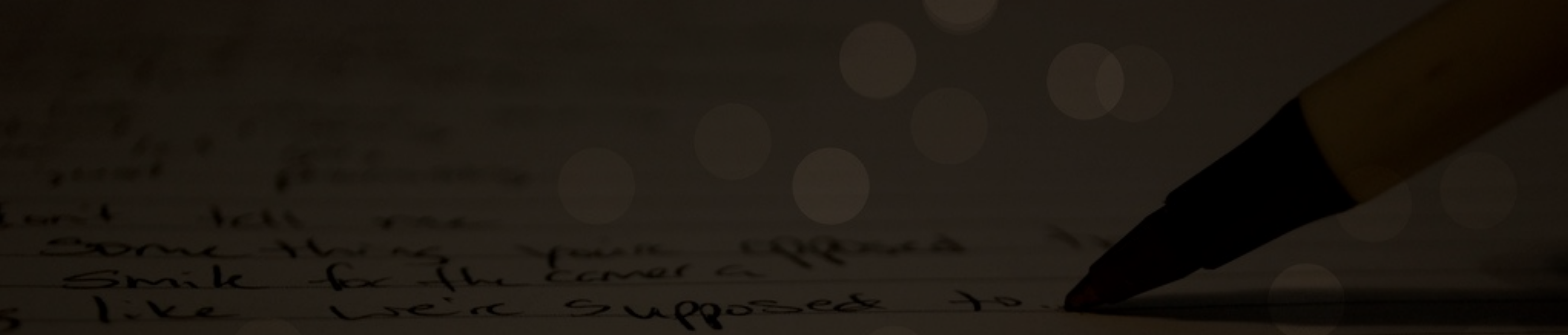

“If you can't tell it, you can't sell it.”

- Peter Guber

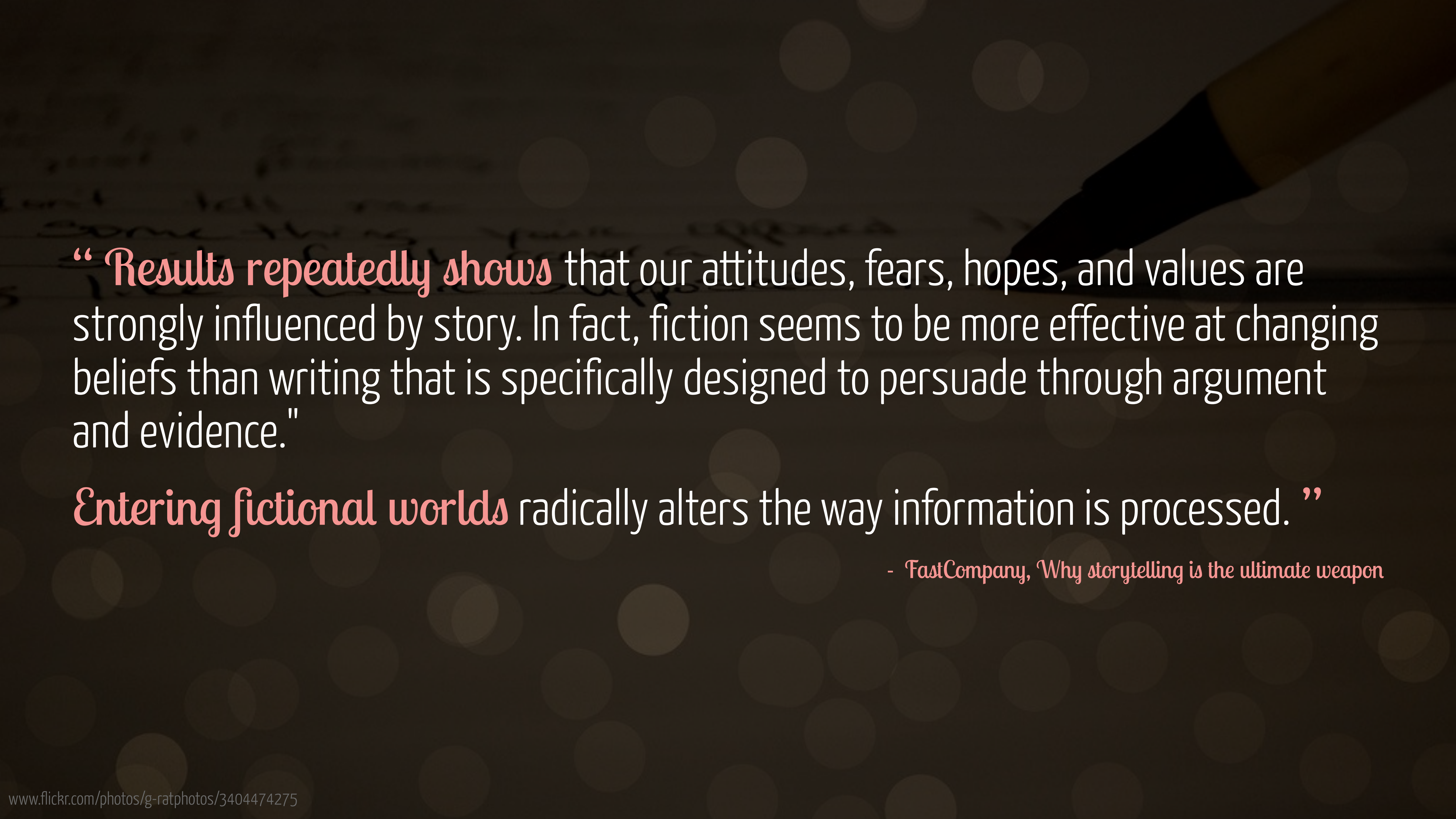

“ **Results repeatedly shows** that our attitudes, fears, hopes, and values are strongly influenced by story. In fact, fiction seems to be more effective at changing beliefs than writing that is specifically designed to persuade through argument and evidence.”

Entering fictional worlds radically alters the way information is processed. ”

- FastCompany, *Why storytelling is the ultimate weapon*

Stories

as persuasion tools

A photograph of a desk with a notebook, pen, and coffee cup. The notebook is open to a page with hand-drawn sketches of mobile app screens. A pen lies across the notebook. A white coffee cup sits on a saucer to the right. The scene is lit with warm, yellowish light.

Not just for messaging but also
an integral part of the design process



“ **Storytelling** is at the heart of everything ”

- Steve Levitt

Stories capture our imagination
& shows us something new





‘ Now you see me. ’



‘ Now you don’t. ’



“**Historically**, stories have always been igniters of action, moving people to do things.”

- Peter Guber

Stories have the ability to motivate,
change & create connections



A teddy bear is seen from behind, walking up a snowy mountain slope. The bear is wearing a grey long-sleeved shirt, olive green pants, and a bright yellow backpack. The sun is low on the horizon to the left, creating a lens flare effect and casting a warm glow over the scene. The background features dark, jagged mountain peaks under a clear sky. The snow in the foreground is textured with small mounds and shadows.

Every story
takes us on a journey

Storytelling can

provide powerful call to actions

HEAR

We do our best
to understand & help



a



b

Google & social are
our new home page

Google



Google Search

I'm Feeling Lucky

A low-angle shot of a construction worker on a wooden and metal structure, possibly a tower or bridge. The worker is wearing a light-colored long-sleeved shirt and khaki pants, leaning forward. The structure consists of wooden planks and metal beams. The background is a clear blue sky with some light clouds. The overall scene is bright and sunny.

*Users now land
smack in the middle*



To some extent we've
lost control

DEVICE FRAGMENTATION

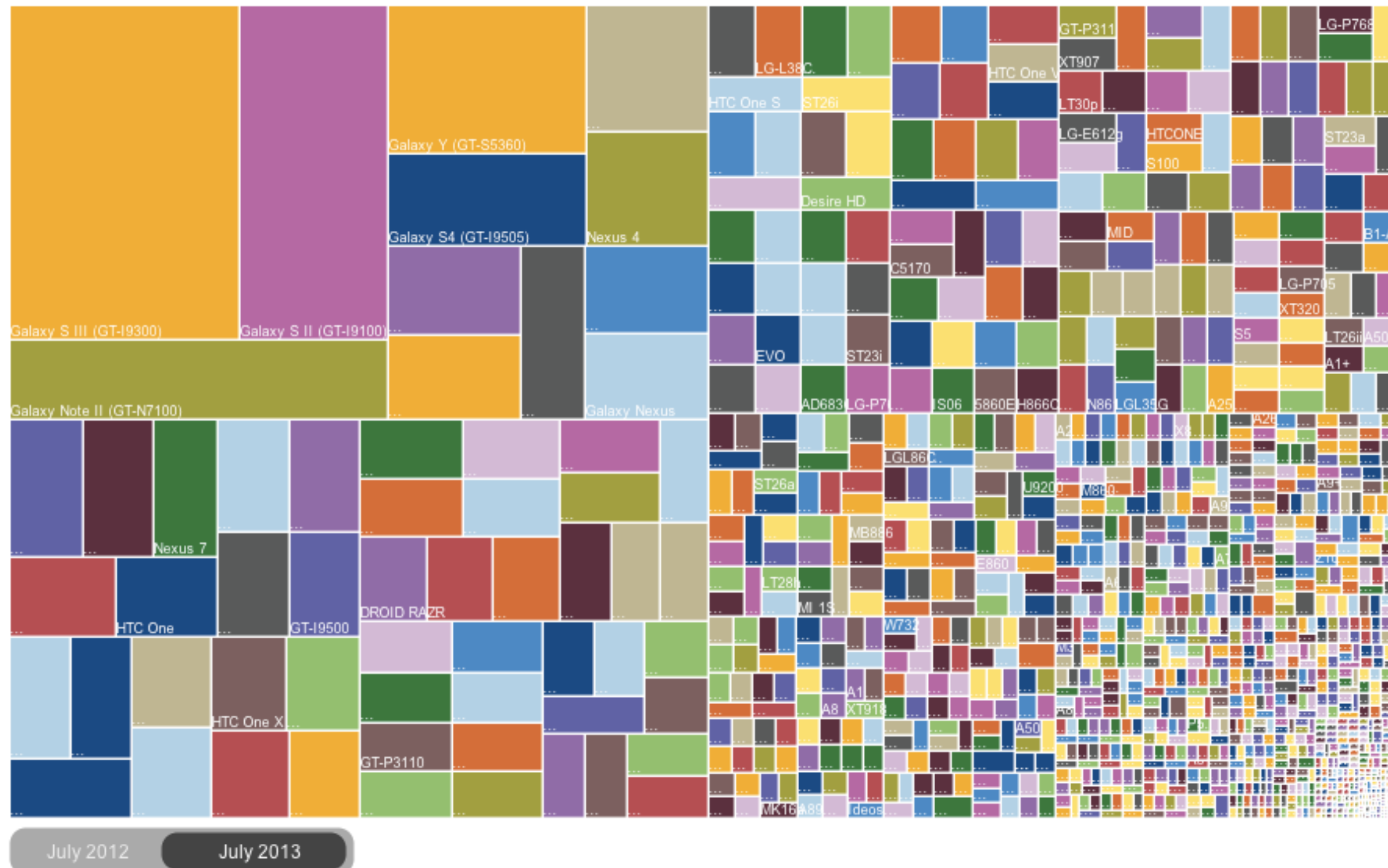

July 2012 July 2013

This is the best way of visualizing the sheer number of different Android devices that have downloaded the OpenSignal app in the past few months. From a developer's perspective, comparing fragmentation from this year to the previous year, we see that it has tripled, with even more [obscure devices](#) from around the world downloading the app. If you want to understand the challenge of building an app that will work on all devices that want to download it, this image is a good place to start!

We have seen 11,868 distinct devices download our app in the past few months. In our report last year we saw 3,997.

DEVICE FRAGMENTATION

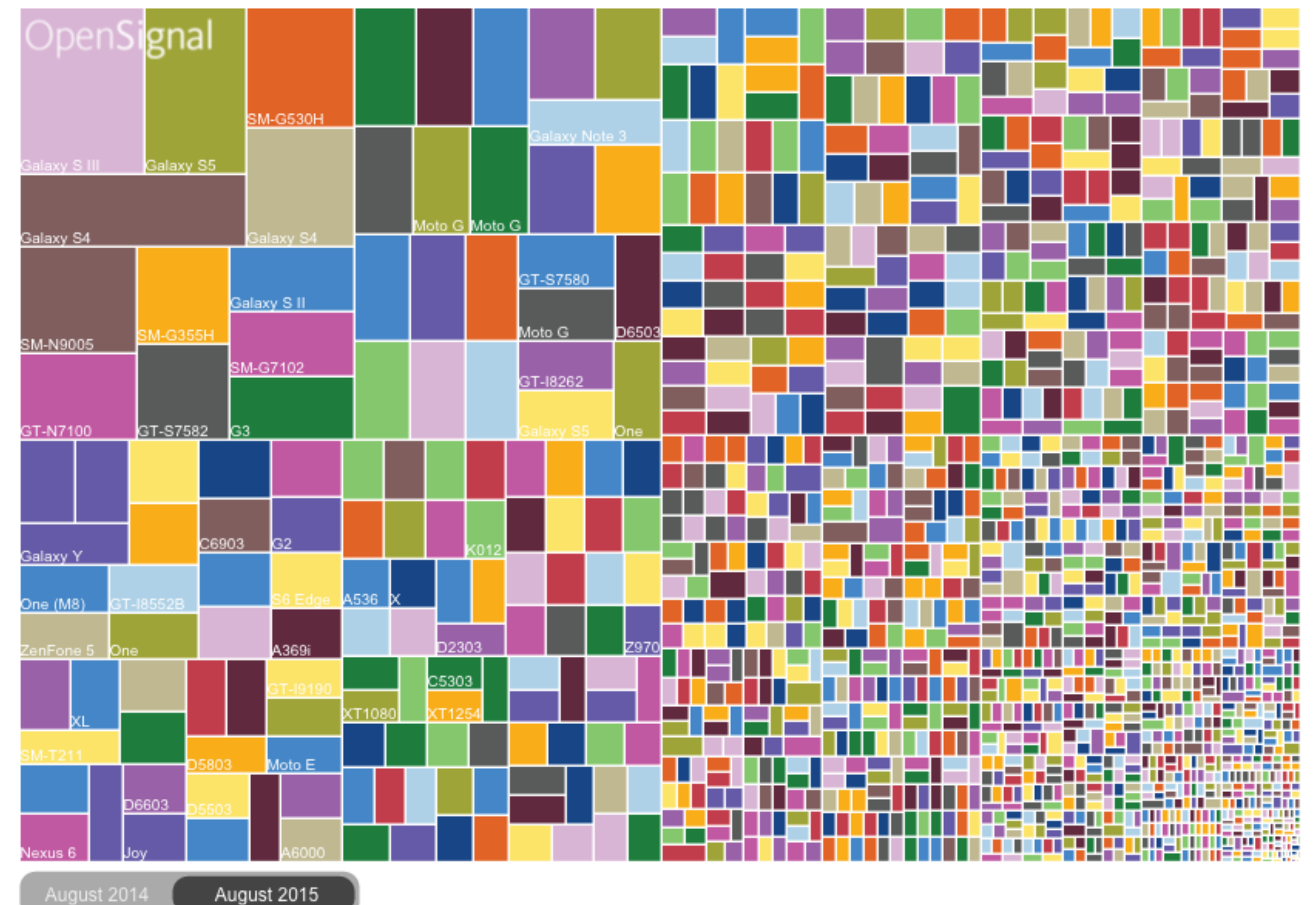

August 2014 August 2015

This is the best way of visualizing the sheer variety of Android devices that have downloaded the OpenSignal app over the past couple of months. This graph shows the challenge that faces Android developers; over 24,000 distinct devices can immediately use their app, making optimization a real challenge. In two years Android Fragmentation has more than doubled from the 11,868 we saw back in 2013.

We have seen 24,093 distinct devices download our app in the past few months. In our report last year we saw 18,796. In 2013 we saw 11,868.

A whole new era for apps.

Apple Watch isn't just a different location for your favourite apps. It's an entirely different way to experience them. A time-saving feature called Glances condenses the most relevant information from each app into a form you can easily scan on the fly. And because Apple Watch can tap you on the wrist, you'll be aware of notifications instantly.

It's the start
of something new



Screenshot: <http://www.apple.com/uk/watch/>

Smart homes are the new smartphones



A screenshot from the movie 'Minority Report' showing Tom Cruise in a futuristic control room. He is wearing black neural interface gloves with glowing blue sensors on the fingers. He is interacting with a large, semi-transparent digital display that shows a 3D wireframe model of a city and various data points. The background is filled with blue light and digital patterns.

*What we previously
only saw in movies...*

7:10AM



MORNING REPORT

7:10AM

CHANNEL 4

IN ORDER TO ELIMINATE DOUBT

SEMI-FINALIST CAUGHT YET

...in concept videos...



SHOWER SETTINGS

COFFEE MAKER: ON FRENCH ROAST

WEATHER

| RIGHT NOW | TODAY | TONIGHT | TOMORROW |
|-------------------------------|-------------------------------|--|--------------------------------------|
| SUNNY 70°F Partly Sunny | SUNNY 75°F Partly Sunny | MOSTLY CLEAR SKIES 69°F Partly Sunny | MORNING RAIN 70°F Partly Sunny |
| HOURLY WEATHER | 3 DAY FORECAST | LIVE WEATHER CAST | |

INTERIOR TEMP 72°F

CENTRAL AIR ON

AC High

Set temp: 72°F



...and more movies,
is happening.



amazon echo

Always ready, connected, and fast. **Just ask.**

“Alexa, play my
Melodifestivalen playlist”



59° 

Light rain tonight and
tomorrow morning

 30%

3:26

Thursday
January 28

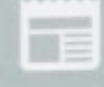
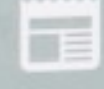
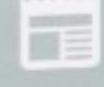
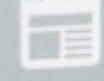
-  AP sources: Panel proposes ban on air shipments of batteries
-  GOP candidates look to make the most of Trump's absence
-  UN health chief: Zika virus is 'spreading explosively'
-  Oregon standoff dwindles to 4 holdouts demanding no arrests



The device
that changed everything

“90% of users start a task on one device and then complete it on another.”

- Source: Google

Sequential usage



Simultaneous usage

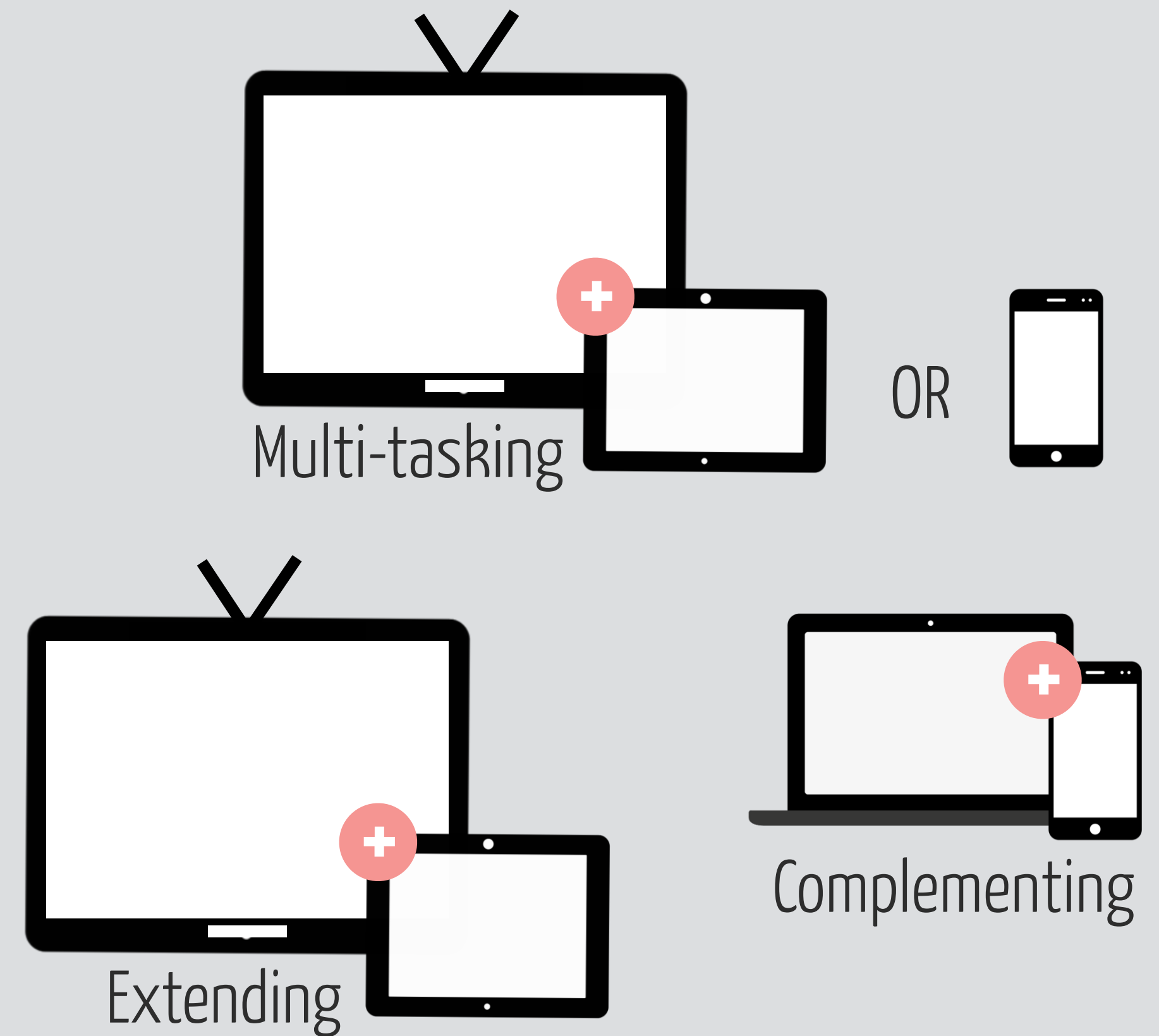

The *basic* structure of a journey



The *basic* structure of a story

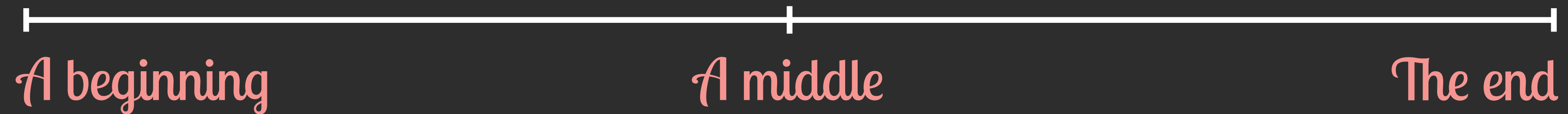

What

makes for a good story?



I asked my dad for
3 principles around good storytelling

01

Captures the imagination

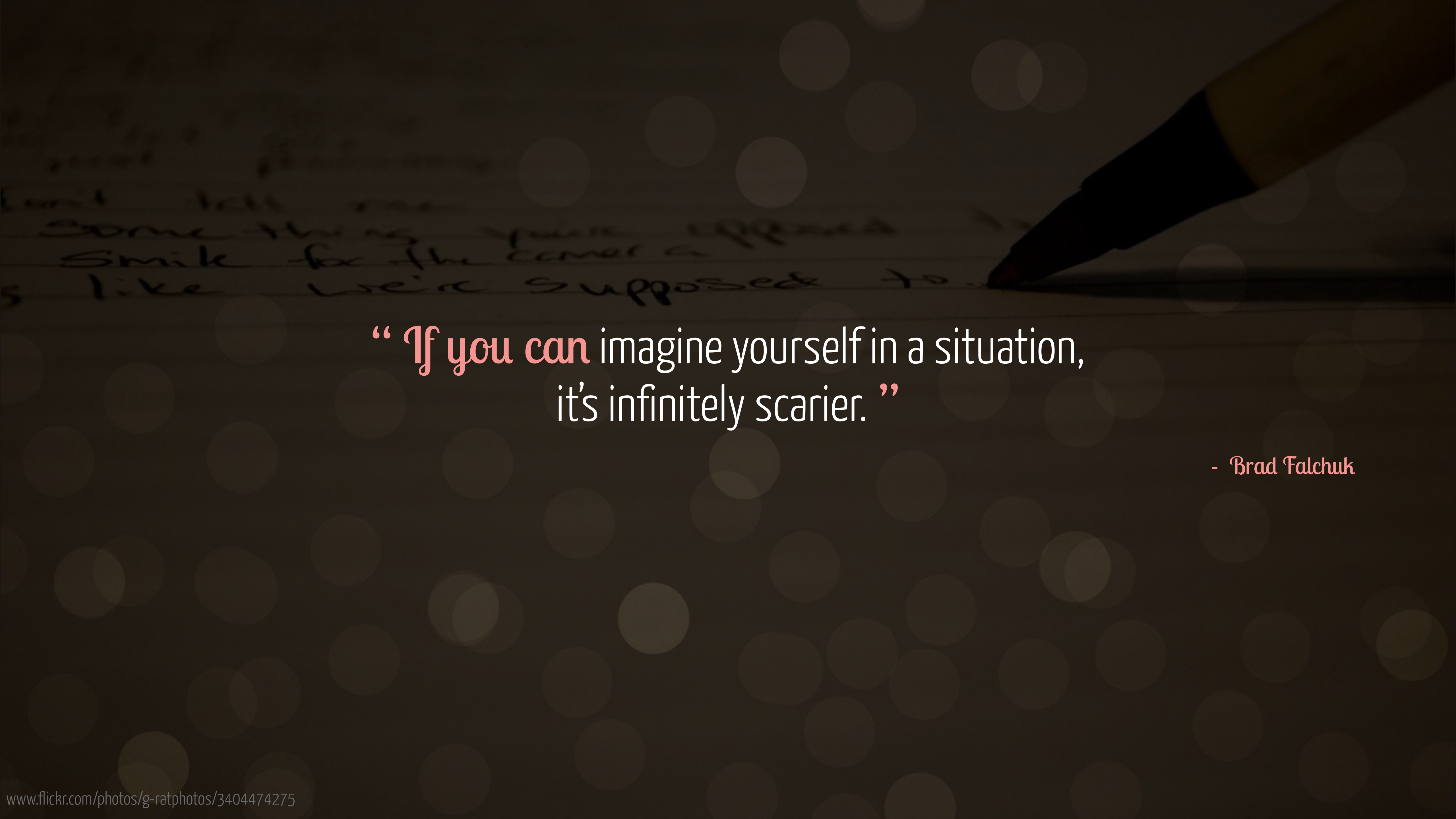

“If you can imagine yourself in a situation,
it’s infinitely scarier.”

- Brad Falchuk

A close-up photograph of a lion's face, focusing on its eyes and nose. The lion has large, dark, glossy eyes with white sclera. Its nose is a prominent white patch. The fur is a mix of golden-brown and lighter tan. The background is dark and out of focus.

Users need to
be able to relate

We need to understand who they are



Janet Kendall New Member

Demographics
Location: Australia (Adelaide)
Age: 42 yrs
Income: \$22k
Qualification: TAFE Diploma
Employer: Local Govt

Background
Janet works with older equipment and software than the industry norm. She is the records management goto person for her local govt council. Which is of major concern to Janet as she is often foundering professionally, feeling isolated and alone with no one to turn to. Janet has looked at the benefits of the RMAA previously and discounted them; but is now interested in some minor degree mentorship. She is hungry for new information and resources she can use with a limited budget.

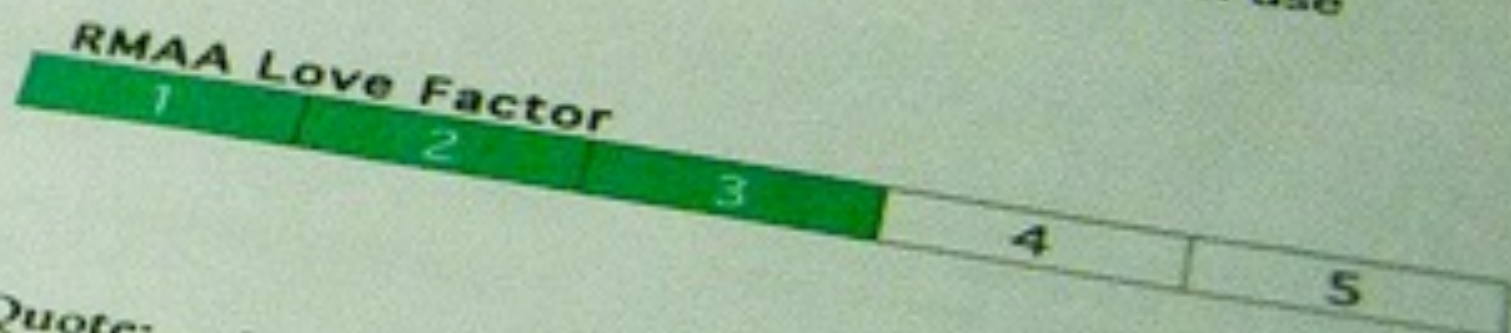

Quote: ...Love going to the RMAA to see what's new that I should know about Upcoming events Branch news



Scott Gilles Student (Member)

Demographics
Location: Australia (Adelaide)
Age: 19yr
Income: \$10k
Qualification: Certificate
Employer: Higher School
University: Studying at Adelaide

Background
Scott is very tech savvy, but gets very impatient if he can't find the information he wants or the system has limitations. He is currently thinking about taking up an internship for the summer break. He uses a Mac at home and a Windows computer at University. For him the RMAA is all about networking and a little socializing. He's been wondering if the RMAA is any use for overseas connections, as he is planning to go around Asia for 6-12 months. Scott's current situation is very...

- Needs**
- Supplement studies
 - Clarification of Benefits
 - Low cost informative educational events
 - Looking for a mentor
 - Networking with future employers

Personality: curious, passionate, enthusiastic, questioning, syndical, easygoing, short-attention span, fast-learner

Motivations

Find discussions on the practices in RMAA

02

The dynamic of the story

A photograph of a man and a pregnant woman standing side-by-side against a weathered wooden wall. The man on the left is wearing a black long-sleeved shirt with "OLD NAVY" printed in white across the chest and blue jeans. The woman on the right is wearing a green short-sleeved t-shirt and blue jeans, with her left hand resting on her pregnant belly. They are holding hands in the center. The background is a rustic wall with peeling white paint and visible wood grain.

OLD NAVY

What are the events
& people that tie it all together

The ever important
"red thread" narrative



03

An element of surprise

“ **In general** there should be a basic idea of where the story is going, but not for every character. You don't know who's going to die and who's going to start becoming more important.

Big picture-wise, there's a basic idea, but you need some surprises too. It's like driving from New York to LA: you know you're going to get to LA, but there's 10 different routes you could take. ”

- Brad Falchuck

ALWAYS BE CURIOUS

Include an element of
surprise & exploration

Let users

WALK YOUR PATH

find their way around your content



How

do we go about it?

How a story is told impacts
the human experience of its audience



Dramaturgy

knowing how to apply & structure
elements to tell a story

Three act structure

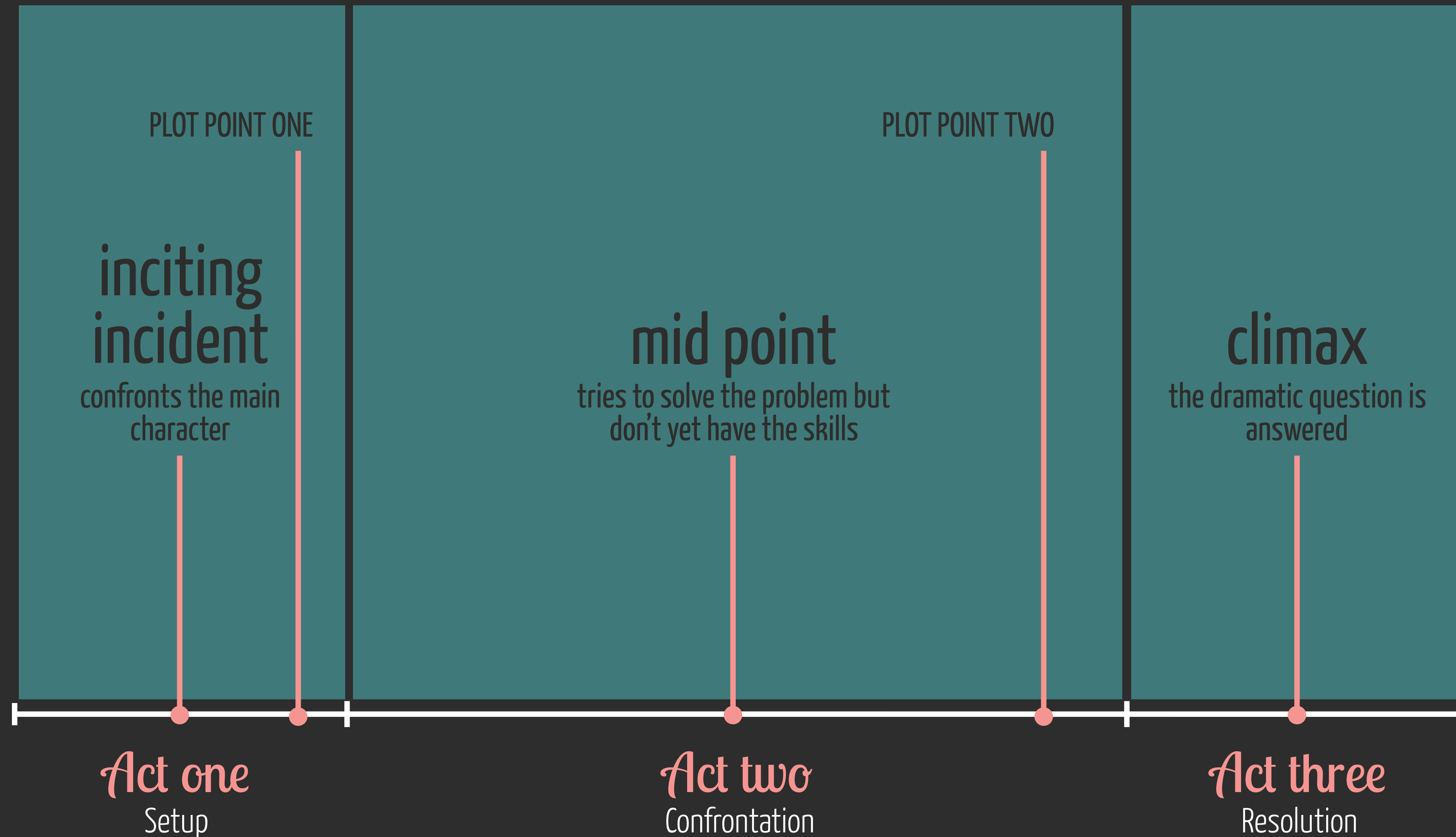

Identify the (product) lifecycle & its stages

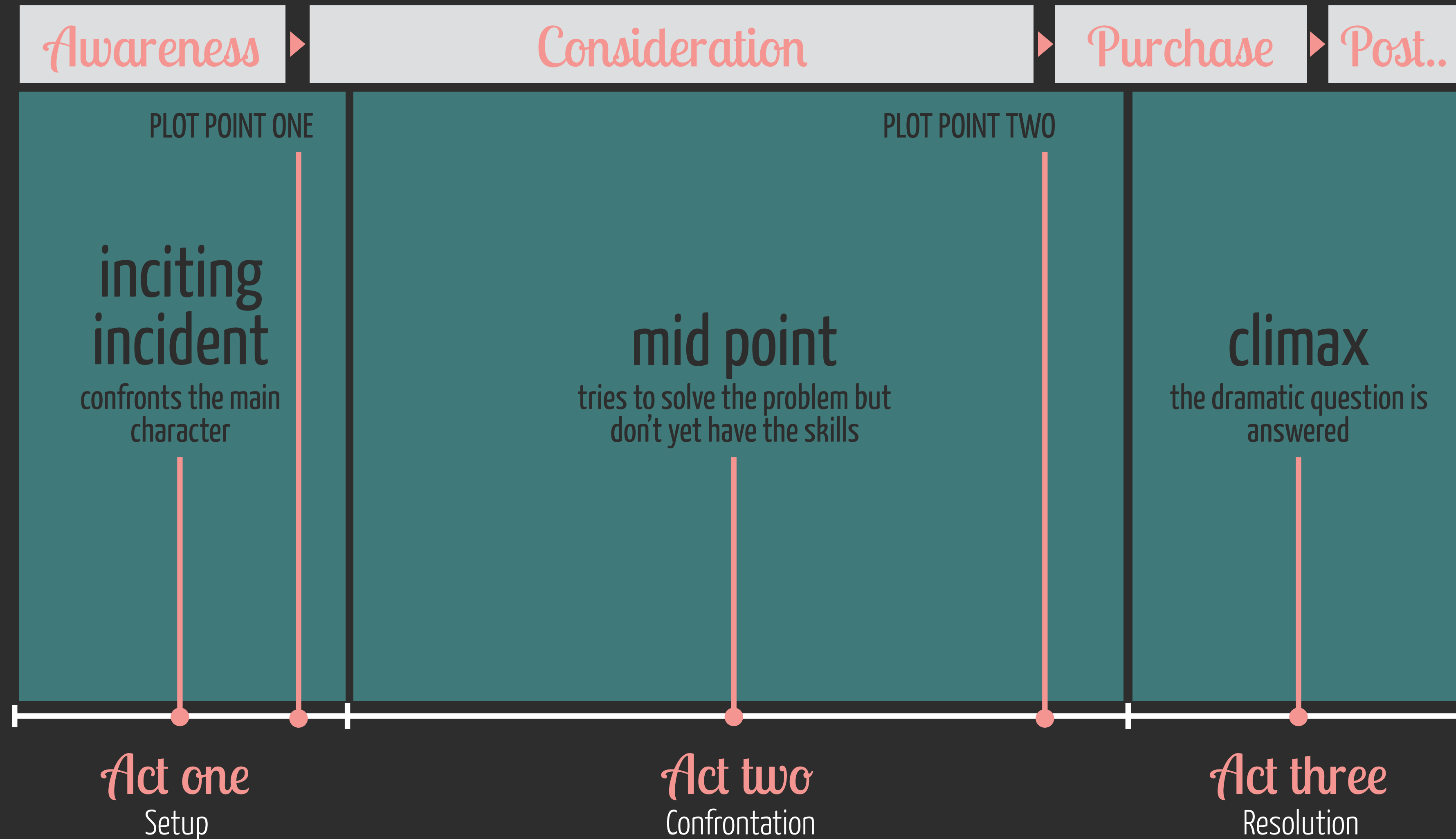

Apply the three act structure

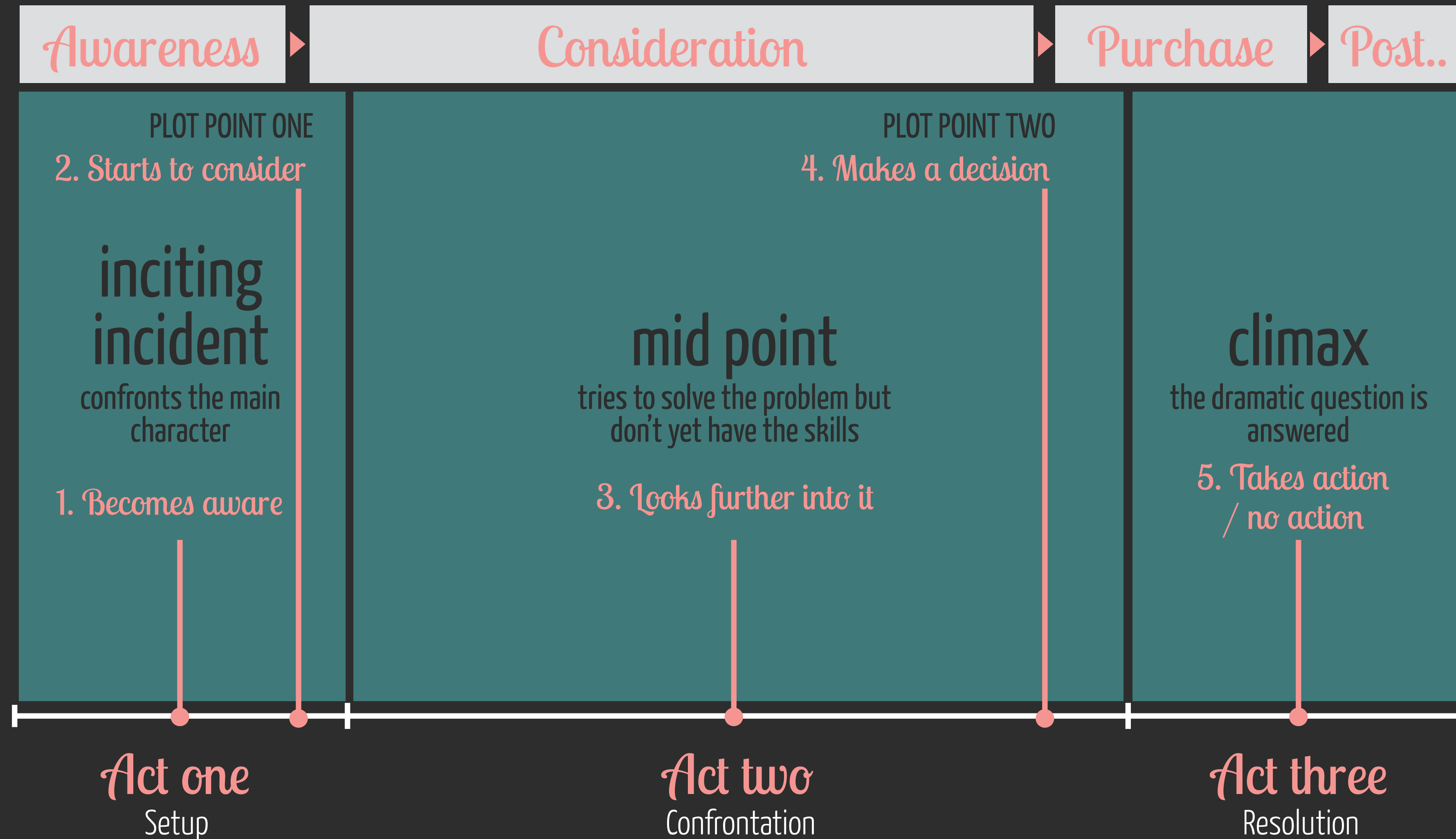

Map the experience

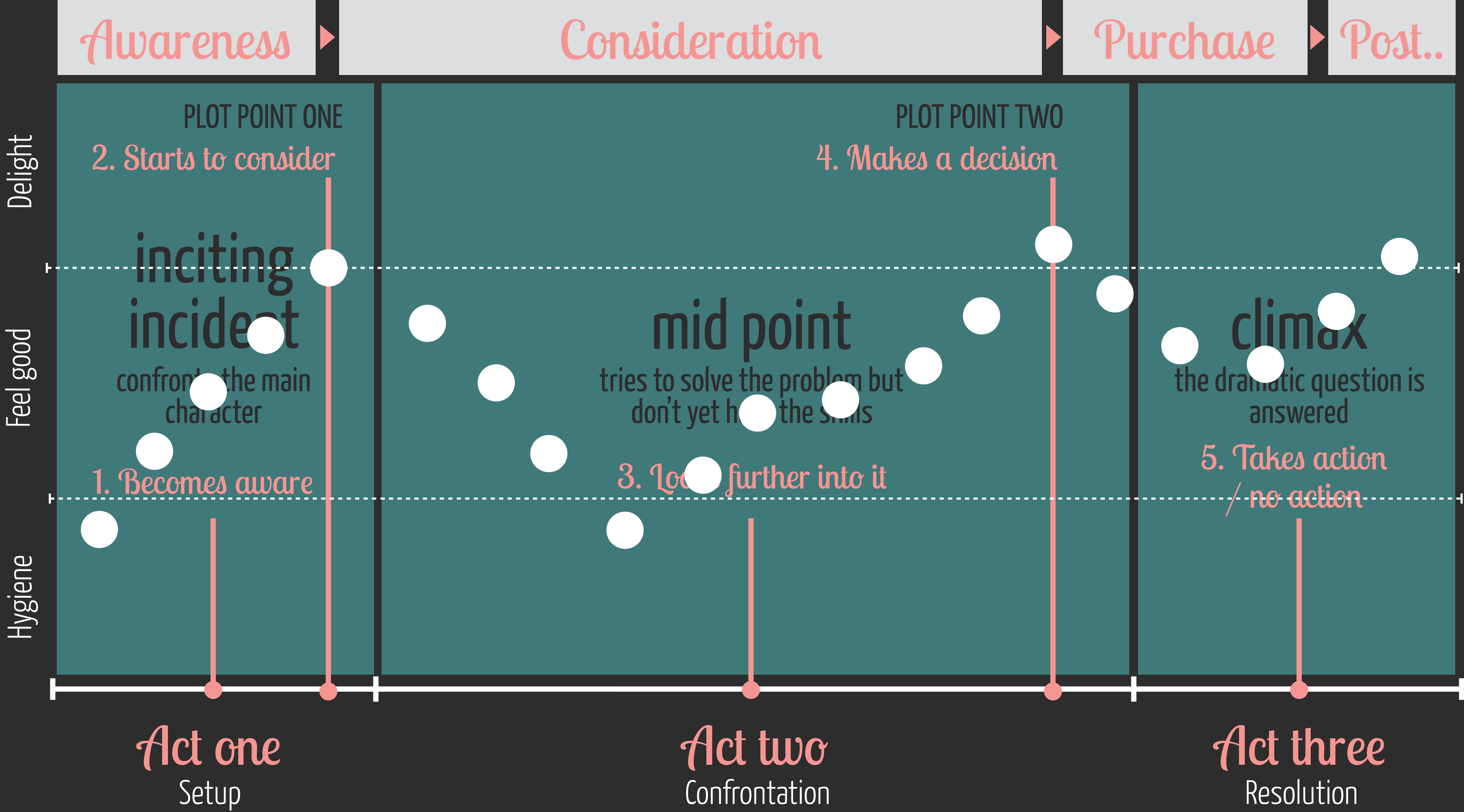

A row of hurdles on a red running track. The hurdles are white with black markings and purple supports. The track has white lane markings. A green field is visible in the background.

Identify where
the biggest barriers may be



Look at where
you want to delight them

Rail Europe Experience Map

Guiding Principles

People choose rail travel because it is convenient, easy, and flexible.

Rail booking is only one part of people's larger travel process.

People build their travel plans over time.

People value service that is respectful, effective and personable.

Customer Journey

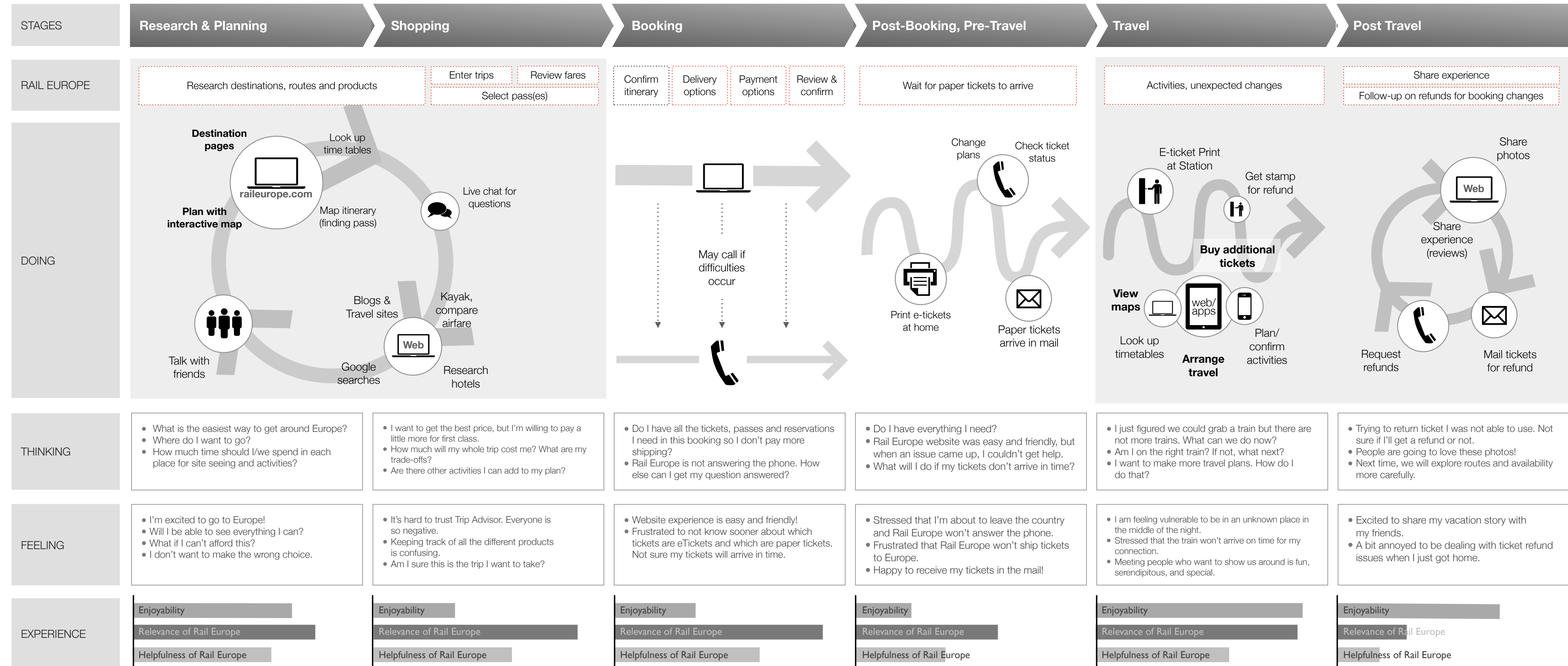

Opportunities

| GLOBAL | | | PLANNING, SHOPPING, BOOKING | | | POST-BOOK, TRAVEL, POST-TRAVEL | |
|--|--|---|--|--|---|---|---|
| <p>Communicate a clear value proposition.</p> <p>STAGE: Initial visit</p> | <p>Help people get the help they need.</p> <p>STAGES: Global</p> | <p>Support people in creating their own solutions.</p> <p>STAGES: Global</p> | <p>Enable people to plan over time.</p> <p>STAGES: Planning, Shopping</p> | <p>Visualize the trip for planning and booking.</p> <p>STAGES: Planning, Shopping</p> | <p>Arm customers with information for making decisions.</p> <p>STAGES: Shopping, Booking</p> | <p>Improve the paper ticket experience.</p> <p>STAGES: Post-Booking, Travel, Post-Travel</p> | <p>Accommodate planning and booking in Europe too.</p> <p>STAGE: Traveling</p> |
| <p>Make your customers into better, more savvy travelers.</p> <p>STAGES: Global</p> | <p>Engage in social media with explicit purposes.</p> <p>STAGES: Global</p> | | <p>Connect planning, shopping and booking on the web.</p> | <p>Aggregate shipping with a reasonable timeline.</p> | | <p>Proactively help people deal with change.</p> <p>STAGES: Post-Booking, Traveling</p> | <p>Communicate status clearly at all times.</p> <p>STAGES: Post-Booking, Post Travel</p> |

Delivering

the right content at the right time on the right device

Storytelling

across devices

01

Define device roles & hand-off points

Any

device
browser
screen
input method
connection speed

Used

anytime
anywhere

Device Preferences Throughout the Day

Most Weekday Tablet Usage Occurs Between 8pm and 9pm

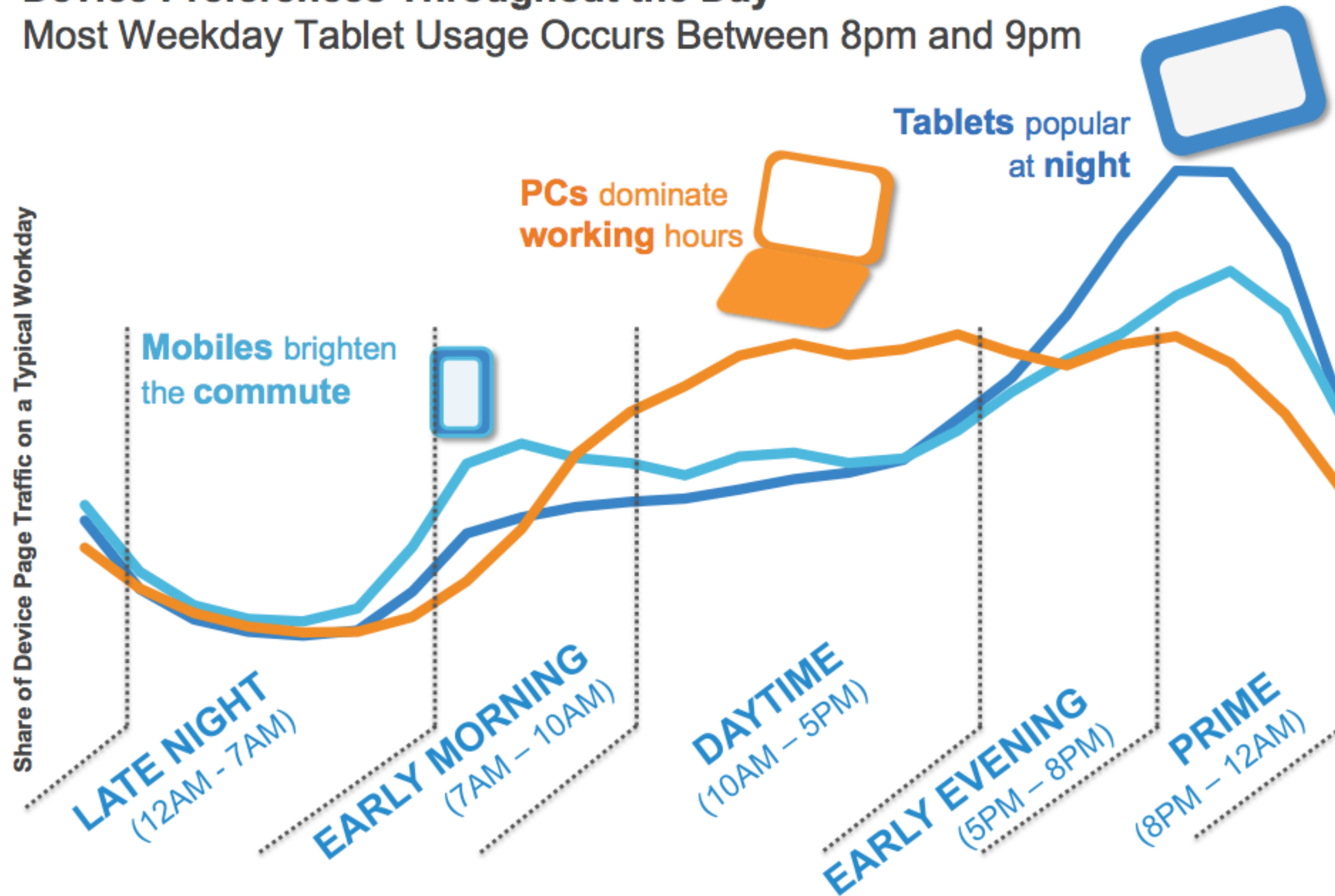

Each device is different.

Make the most of it



| | | | | |
|--------------|---|---|---|---|
| Browse | ✓ | ✓ | ✓ | |
| Research | ✓ | ✓ | ✓ | |
| Buy & Pay | ✓ | ✓ | ✓ | ✓ |
| Get notified | | | ✓ | ✓ |

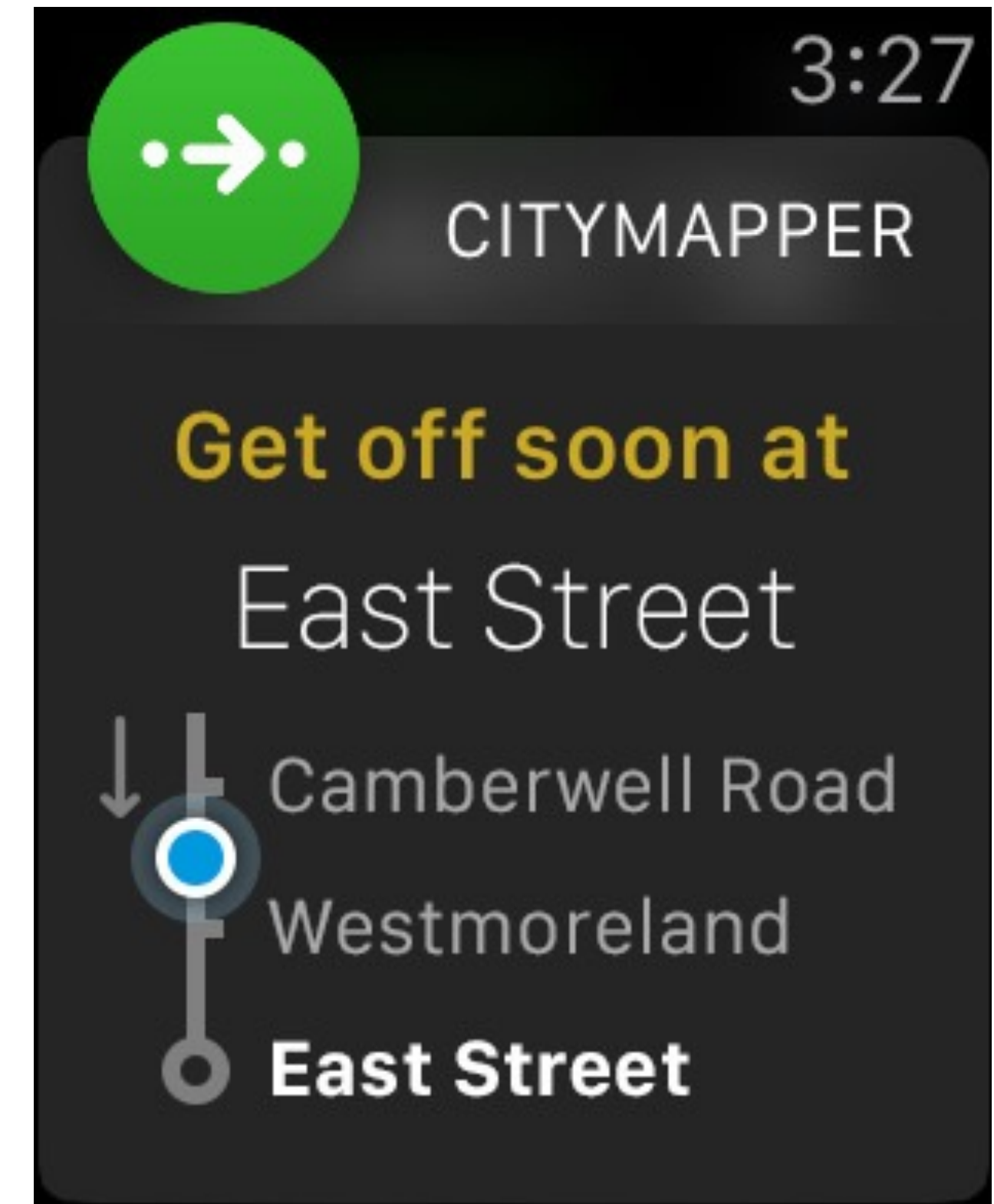
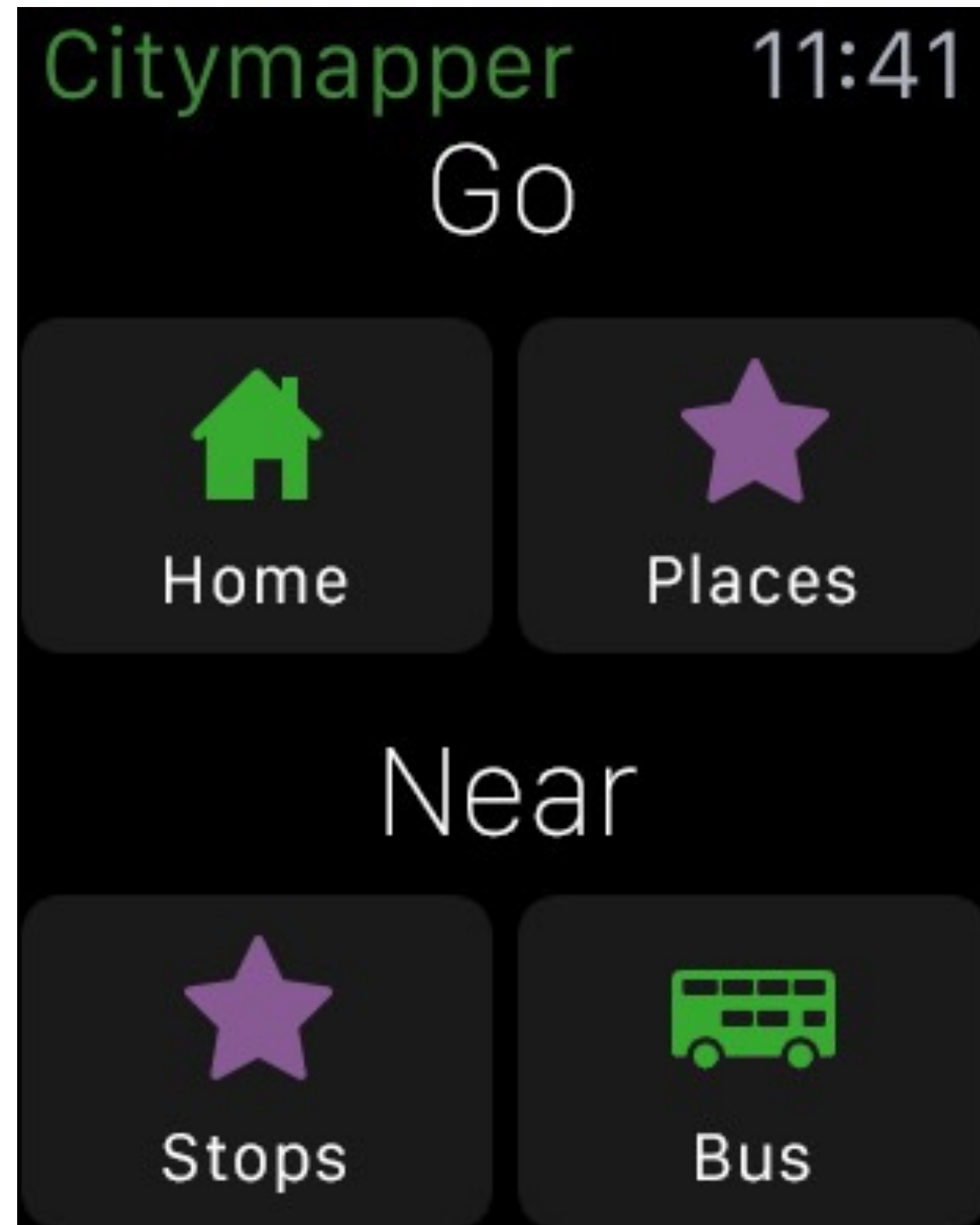

02

Design systems of components



1x

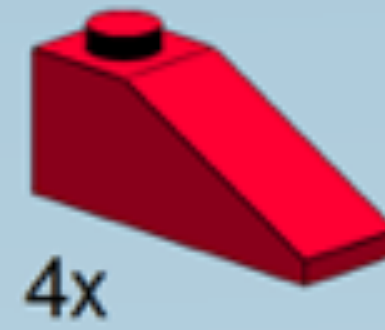
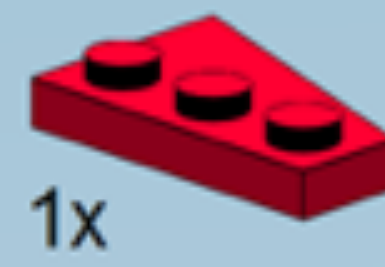
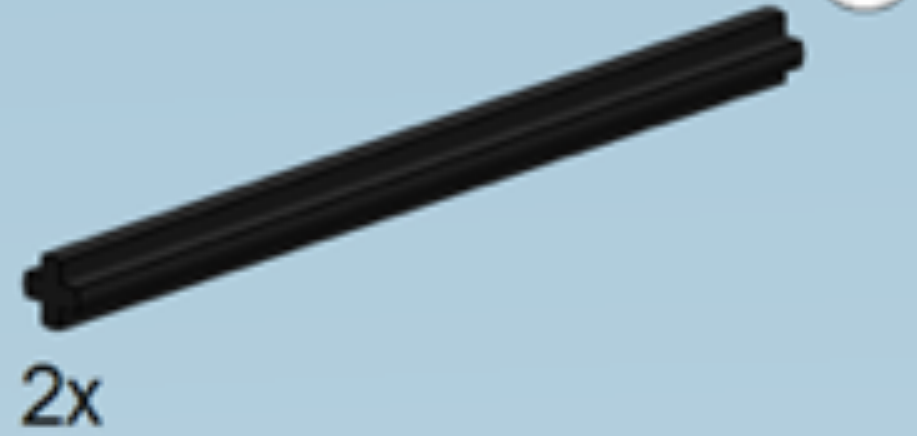

2x



2x



2x



2x



2x



4x



8x



2x



4x

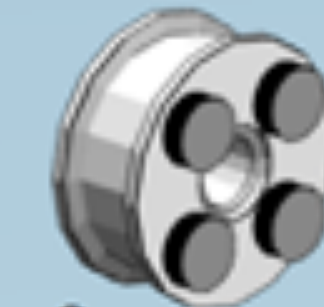

3x



2x



1x



8x



1x



5x



8x



2x



5x



2x



1x



3x



4x

Designing for multiple devices

is a bit like building lego

33x



2x



1x

5x



1x



5x

2x



4x



2x



4x

2x



3x

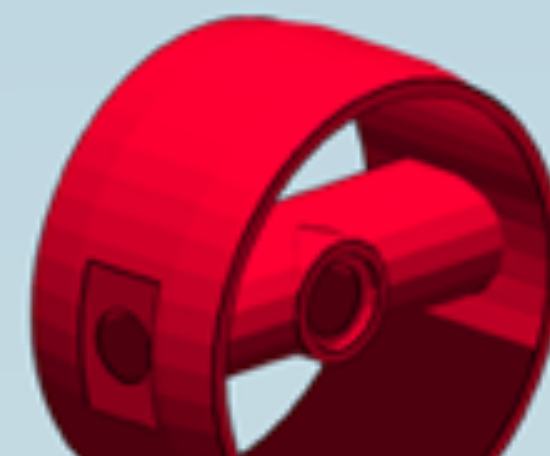

It's about modules rather than pages

Home - large

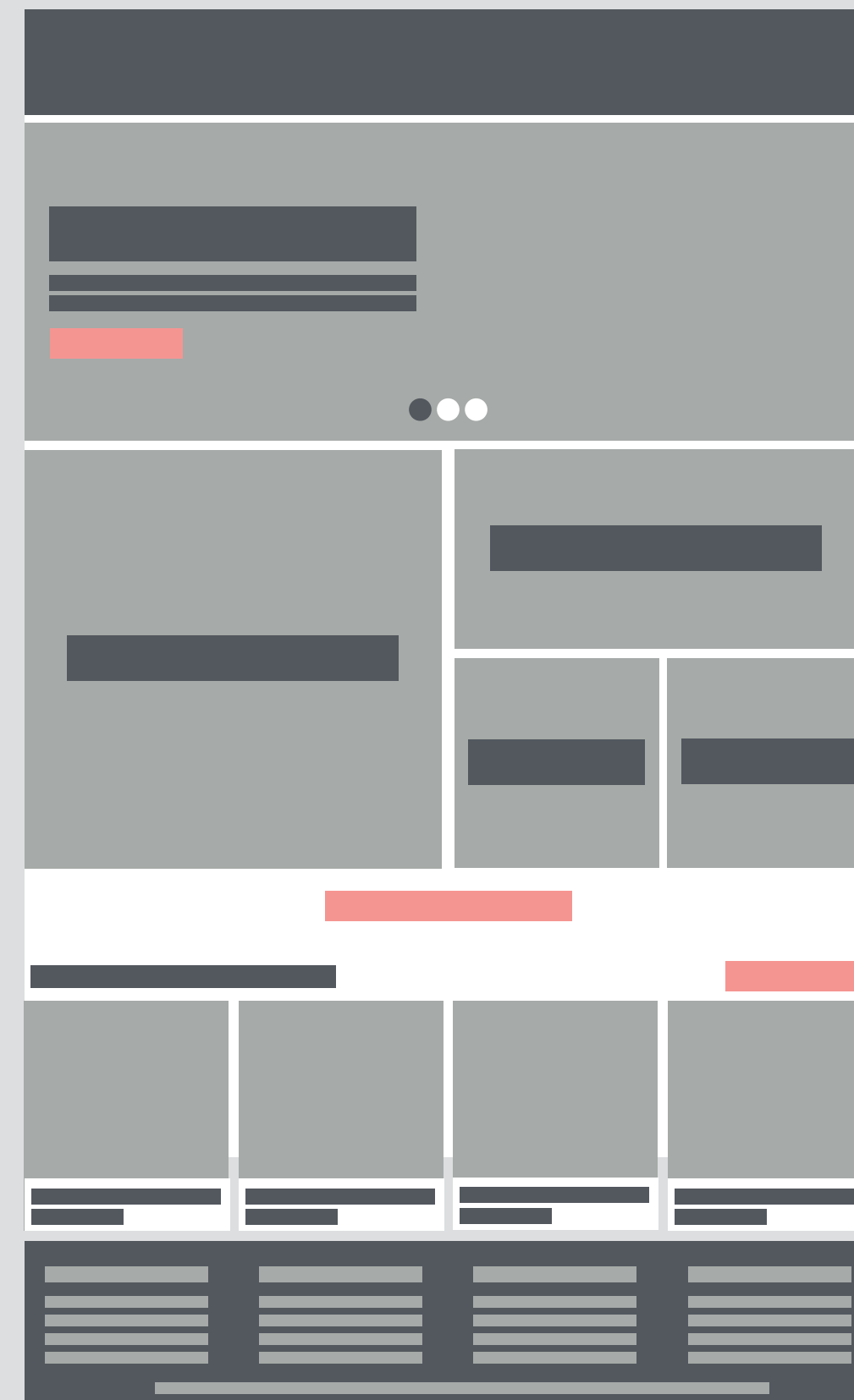
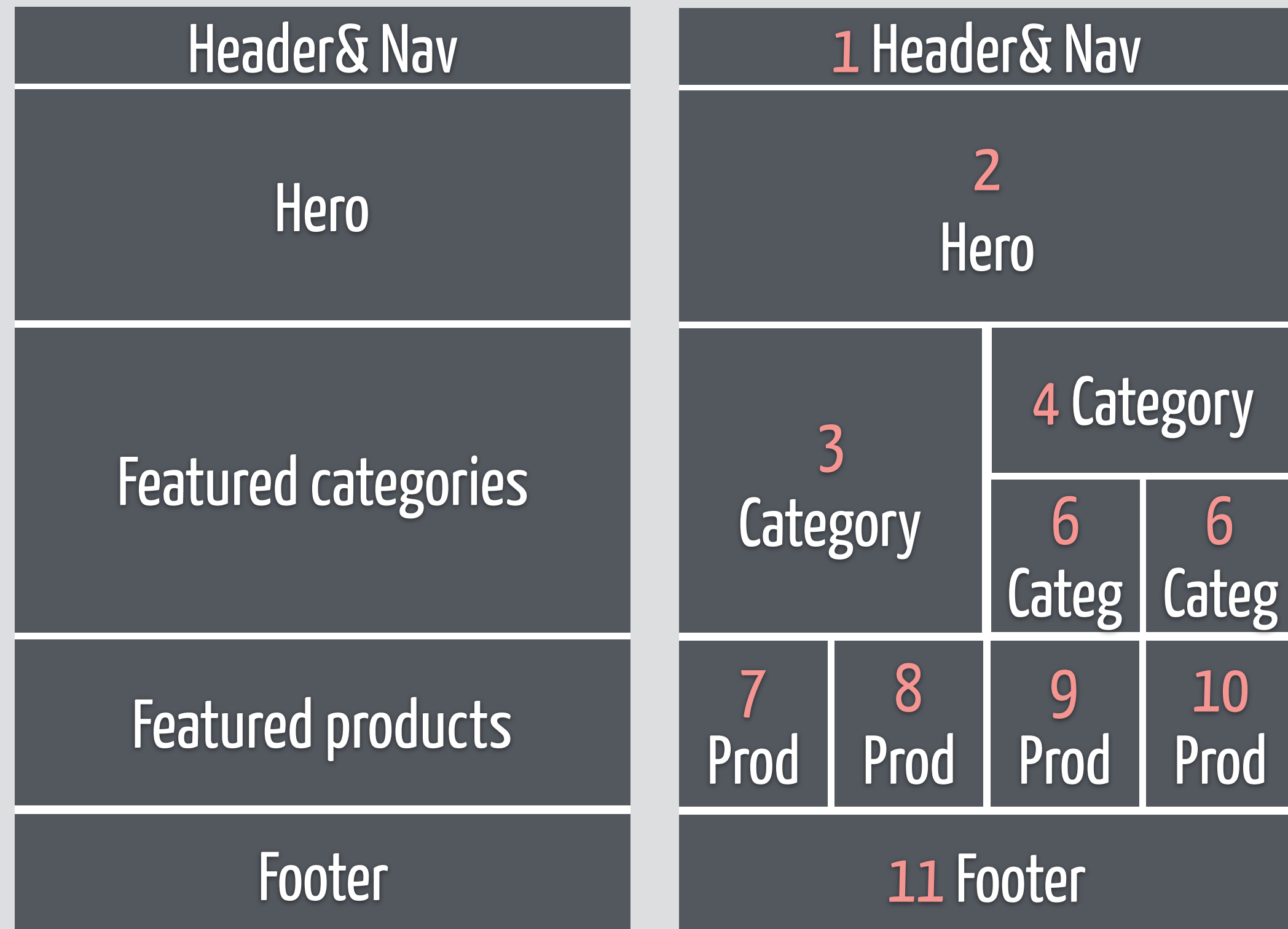

Home - small

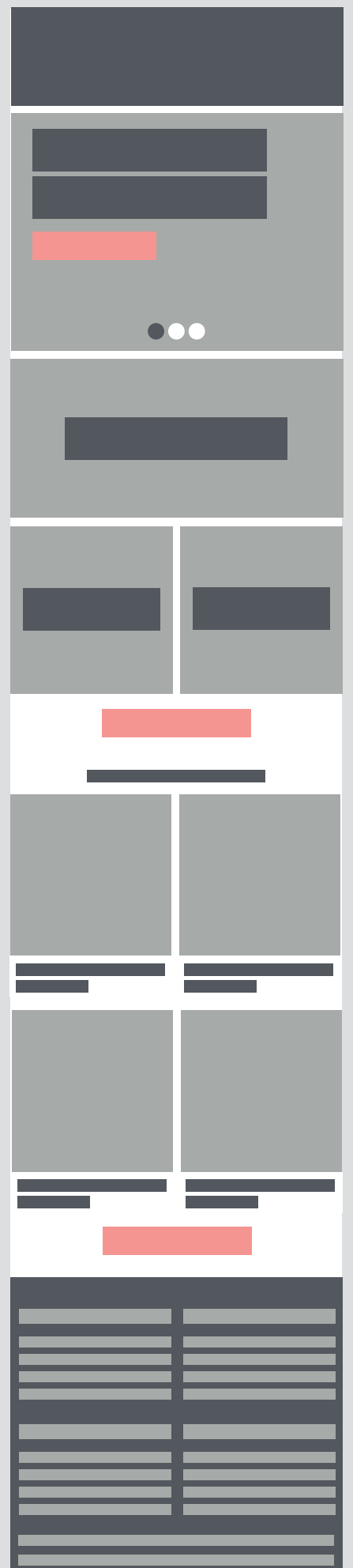
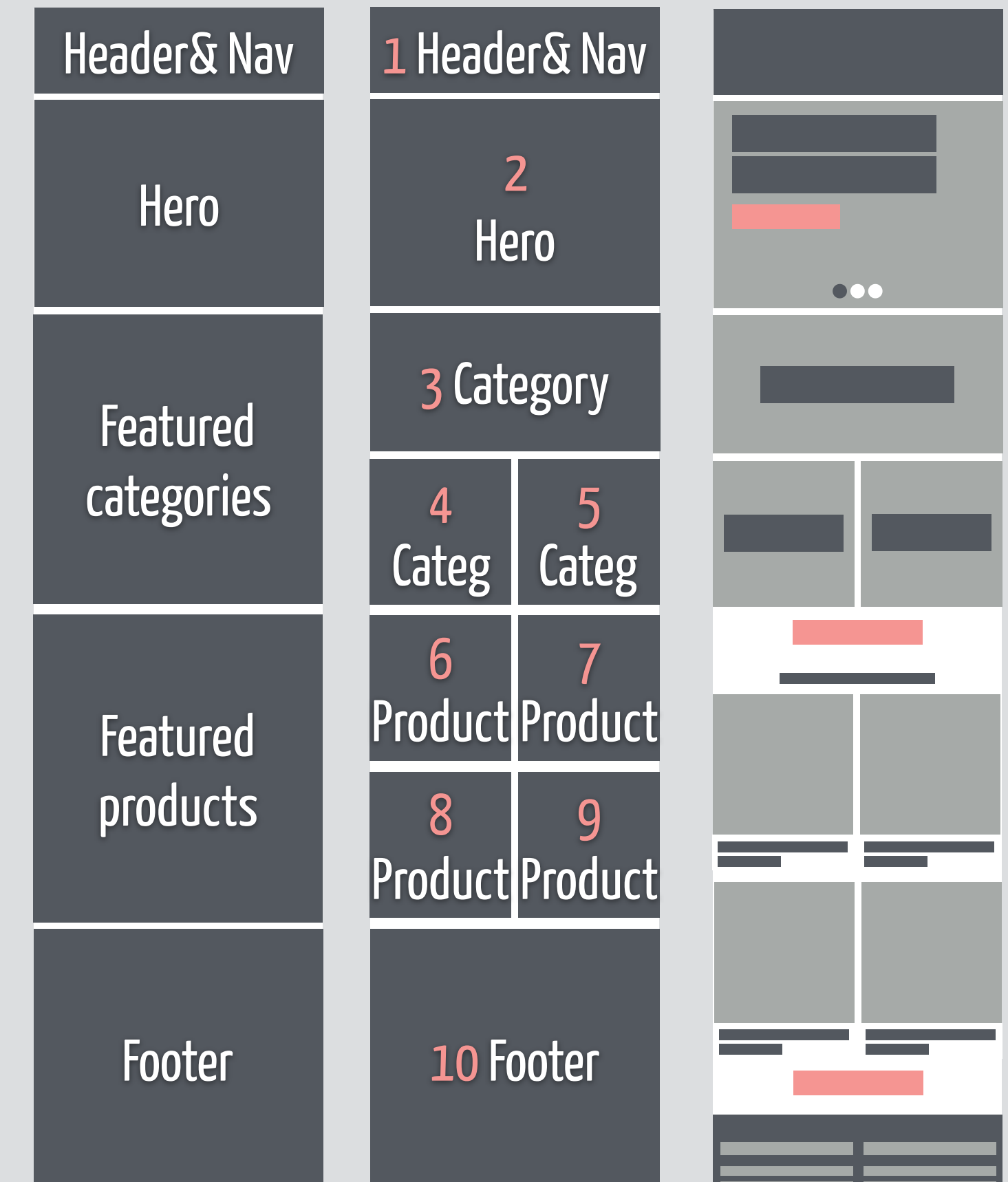

Gradually build your module library

Hero - large

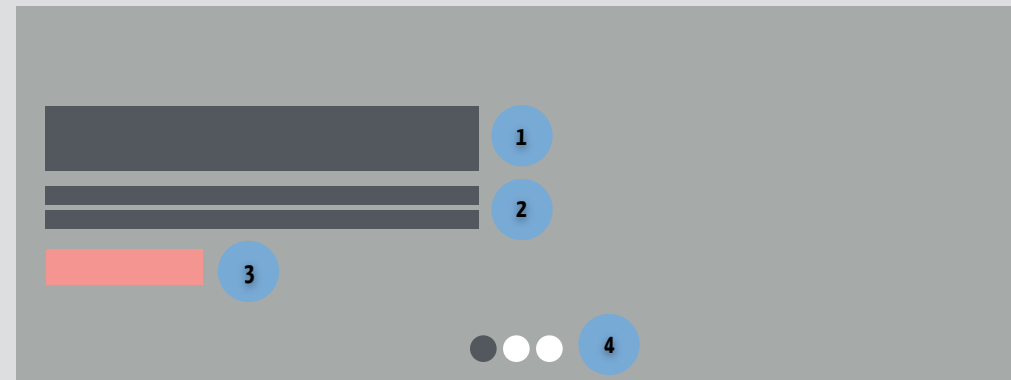

Hero - small

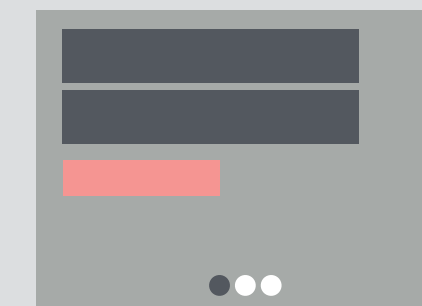

Featured products - large

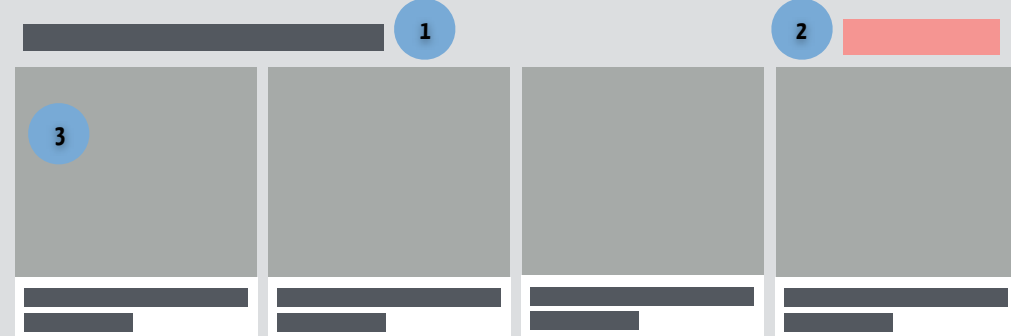

Also used for:

- Module RELO1 - Related products

Featured products - small

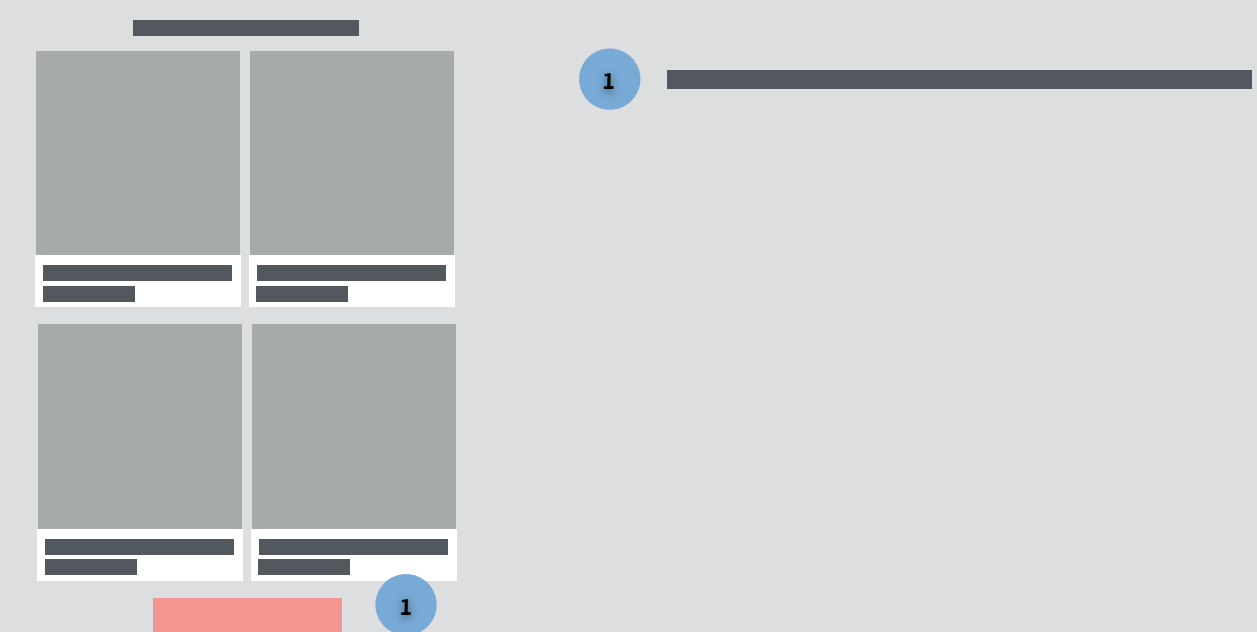

Single product - large

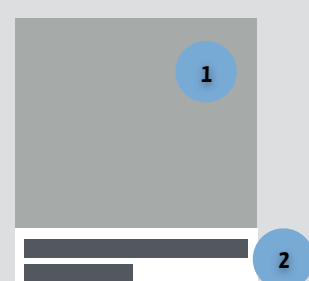

Single product - small



Making sure it works across devices...



7:10AM



MORNING REPORT

7:10AM

CHANNEL 4

...IDER TO ELIMINATE DOUBT

SEMI-FINALIST CAUGHT YET

...and can go
anywhere



SHOWER SETTINGS

COFFEE MAKER: ON FRENCH ROAST

WEATHER

| RIGHT NOW | TODAY | TONIGHT | TOMORROW |
|-------------------------------|-------------------------------|--|--------------------------------------|
| SUNNY 70°F Partly Sunny | SUNNY 75°F Partly Sunny | MOSTLY CLEAR SKIES 69°F Partly Sunny | MORNING RAIN 70°F Partly Sunny |
| HOURLY WEATHER | 3 DAY FORECAST | LIVE WEATHER CAST | |

INTERIOR TEMP 72°F

CENTRAL AIR ON

AC High

Set temp: 72°F



03

Consider notifications part of the interface

A photograph of a traffic light with a 'СТОП' sign, set against a clear blue sky. The traffic light has three lenses: red at the top, yellow in the middle, and green at the bottom. The sign is white with black Cyrillic letters. The text is overlaid on the image.

“ *They should* demand our attention only at truly demanding moments. ”

- *Josh Clark,*
Smart Watches, Wearables, and That Nasty Data Rash

A whole new era for apps.

Apple Watch isn't just a different location for your favourite apps. It's an entirely different way to experience them. A time-saving feature called Glances condenses the most relevant information from each app into a form you can easily scan on the fly. And because Apple Watch can tap you on the wrist, you'll be aware of notifications instantly.

It's starting
to know me



Screenshot: <http://www.apple.com/uk/watch/>

RING

Less annoying
& more useful

Screenshot <http://www.apple.com/uk/watch/>

04

Consider the wider context

A talks to *B* talks to *C*
talks to *D* talks to ...

... understands *the user*

Results for "Fitbit Nest Thermostat"

[← Browse Recipes](#)

Search

2 Recipes found

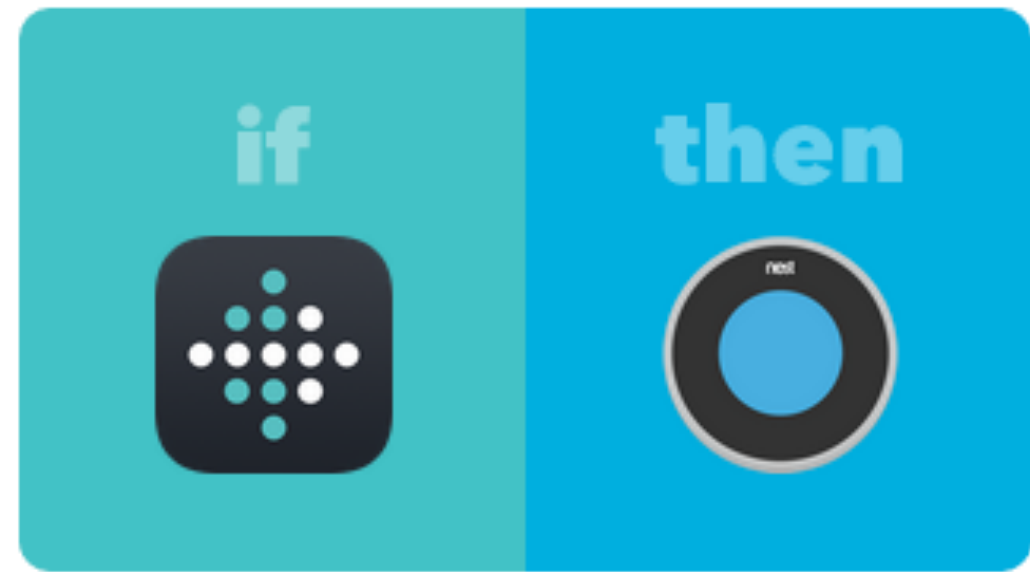

Wake up to heat

by [ksilvester](#)

39 adds 2 favorites

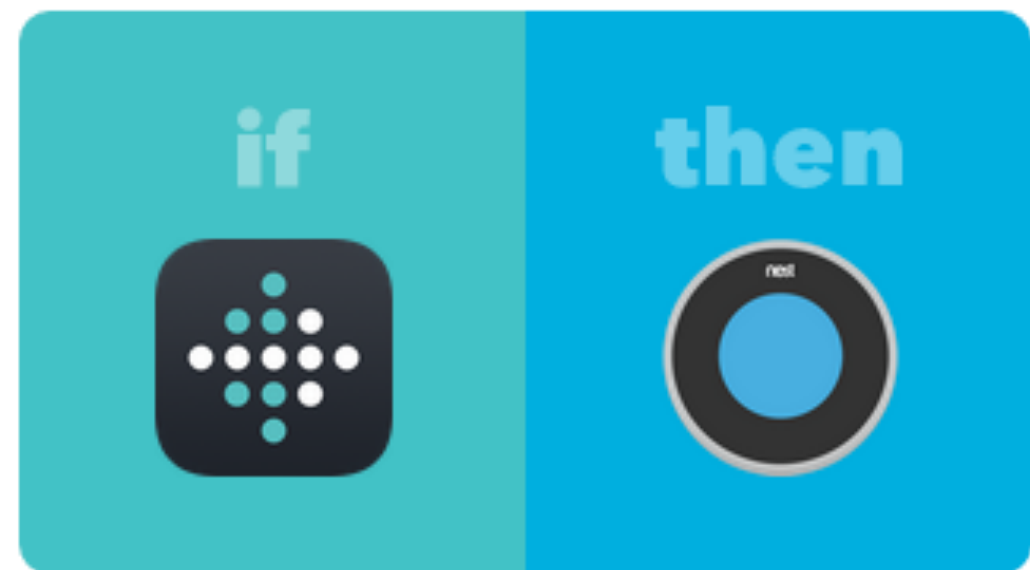

Set Nest to low temp when u're sleeping

by [pblancka](#)

0 adds 0 favorites

05

Cater for different input methods



We're not her(e)

just yet, but...





Mac

iPad

iPhone

Watch

TV

Music

Support



Experience

Entertainment

Games and More

Music and Photos

Tech Specs

Buy



A TV experience
you've never experienced.

Source: apple.com

www.apple.com/apple-tv/4732700819

06

Embrace the chaos

Plan for multiple entry & exit points





Consider non-linear
& new forms of storytelling



Rail Europe Experience Map

Guiding Principles

People choose rail travel because it is convenient, easy, and flexible.

Rail booking is only one part of people's larger travel process.

People build their travel plans over time.

People value service that is respectful, effective and personable.

Customer Journey

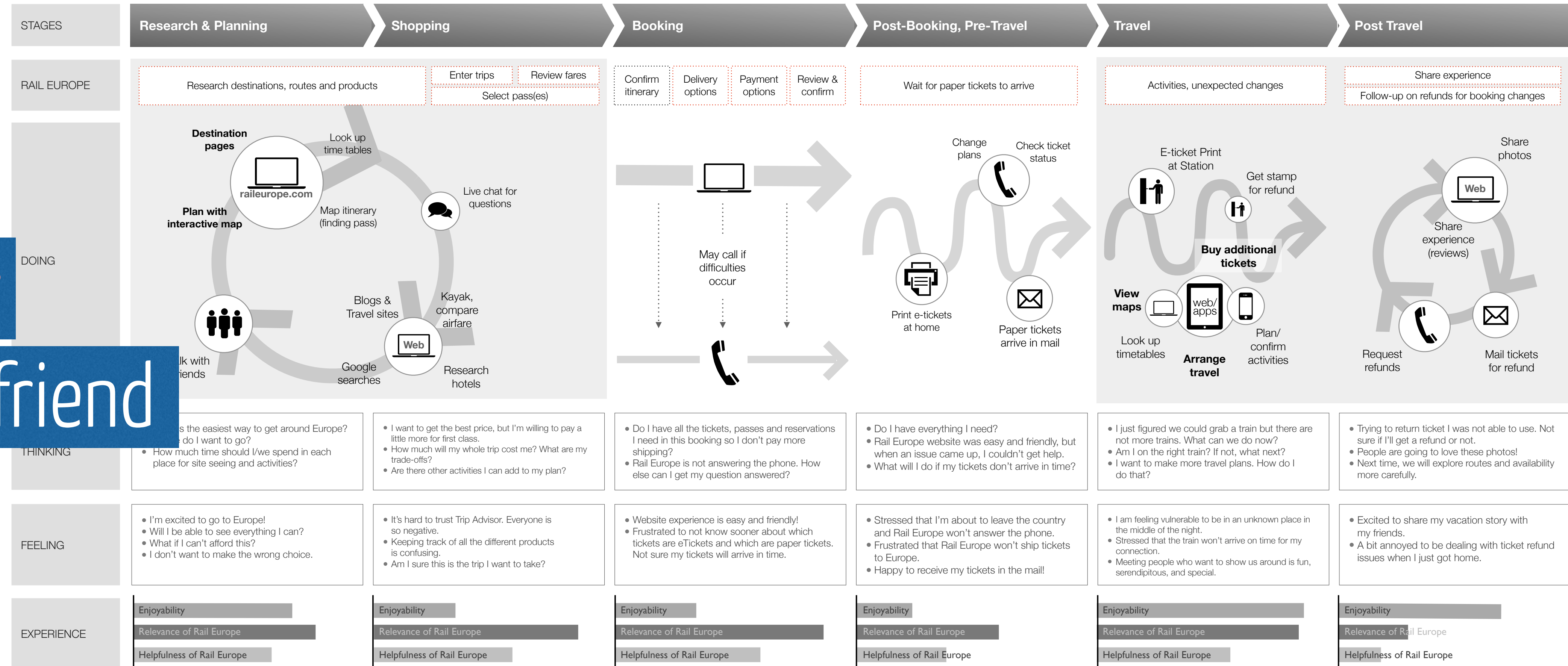

Your best friend

Opportunities

| GLOBAL | | | PLANNING, SHOPPING, BOOKING | | | POST-BOOK, TRAVEL, POST-TRAVEL | |
|--|--|---|--|--|---|---|---|
| <p>Communicate a clear value proposition.</p> <p>STAGE: Initial visit</p> | <p>Help people get the help they need.</p> <p>STAGES: Global</p> | <p>Support people in creating their own solutions.</p> <p>STAGES: Global</p> | <p>Enable people to plan over time.</p> <p>STAGES: Planning, Shopping</p> | <p>Visualize the trip for planning and booking.</p> <p>STAGES: Planning, Shopping</p> | <p>Arm customers with information for making decisions.</p> <p>STAGES: Shopping, Booking</p> | <p>Improve the paper ticket experience.</p> <p>STAGES: Post-Booking, Travel, Post-Travel</p> | <p>Accommodate planning and booking in Europe too.</p> <p>STAGE: Traveling</p> |
| <p>Make your customers into better, more savvy travelers.</p> <p>STAGES: Global</p> | <p>Engage in social media with explicit purposes.</p> <p>STAGES: Global</p> | | <p>Connect planning, shopping and booking on the web.</p> | <p>Aggregate shipping with a reasonable timeline.</p> | | <p>Proactively help people deal with change.</p> <p>STAGES: Post-Booking, Traveling</p> | <p>Communicate status clearly at all times.</p> <p>STAGES: Post-Booking, Post Travel</p> |

07

Design for the individual

Users
are different

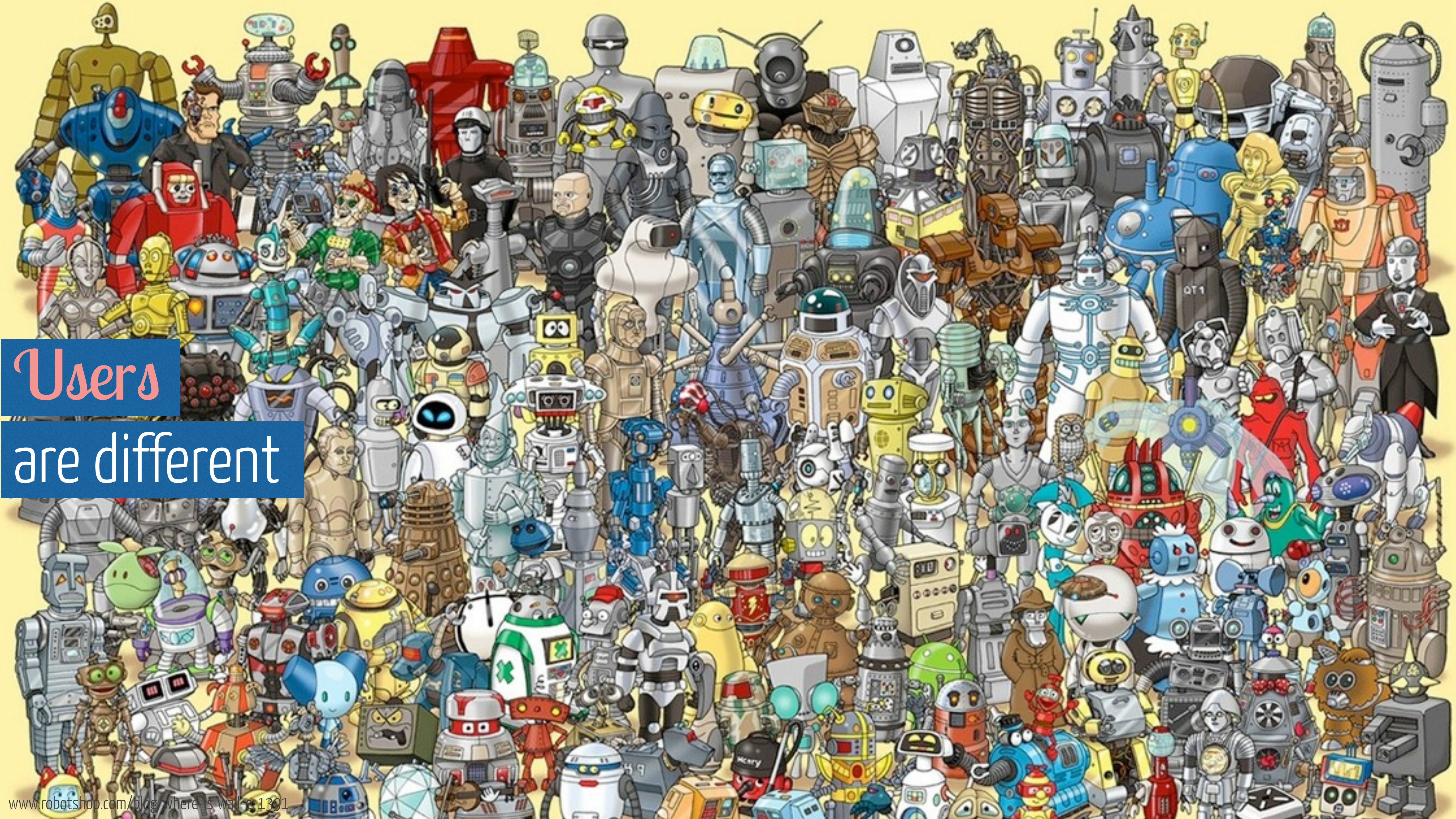

The image features a silhouette of Mickey Mouse on the left and a man on the right, both holding hands. They are set against a background of a sunset or sunrise, with the warm orange and yellow light of the sky. In the foreground, the dark silhouettes of castle spires and flags are visible, suggesting a theme park setting like Disney World. The overall mood is nostalgic and hopeful.

“ If you want to imagine how the world will look in just a few years, [...] skip Silicon Valley. Go to Disney World. ”

- *Wired*
Disney's One Million Bet on A Magical Wristband



“Are virtual assistants the new search?”

- Fortune Tech Debate
Facebook, Google And The Battle For Intent



“Absolutely.”

- Fortune Tech Debate
Facebook, Google And The Battle For Intent

08

Content + Context is king

A single yellow banana is shown against a white background. The words "Buy Now" are written in black marker on the side of the banana. A dark blue horizontal bar is overlaid on the left side of the image, containing white text.

To deliver value we must understand
the reason & intent behind actions



Prior knowledge &
“who” plays a key role

09

Timing is everything



What & What not



Martin Belam
@MartinBelam



Following

Massive 🙌🙌 to BT Sport for scheduling a "Hi can we sell you extra services?" call to me while the #EuropaLeague is on

FAVORITE

1



6:28 PM - 22 Oct 2015

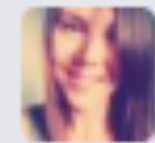

Reply to @MartinBelam

Trends

#NationalCatDay #FocusTonight #GOPDebate #HTGAWM Bob Ross Halloween
Gopalganj #wd15 America Tim Fargo

10

Work with experience goals

The image features a dark, atmospheric background with silhouettes of Mickey Mouse and a man holding hands. Mickey Mouse is on the left, and the man is on the right. They are set against a sunset sky with the spires of a castle, likely Cinderella Castle at Disney World, visible in the distance. The overall mood is nostalgic and hopeful.

“ If you want to imagine how the world will look in just a few years, [...] skip Silicon Valley. Go to Disney World. ”

- *Wired*
Disney's One Million Bet on A Magical Wristband

Map out experience goals

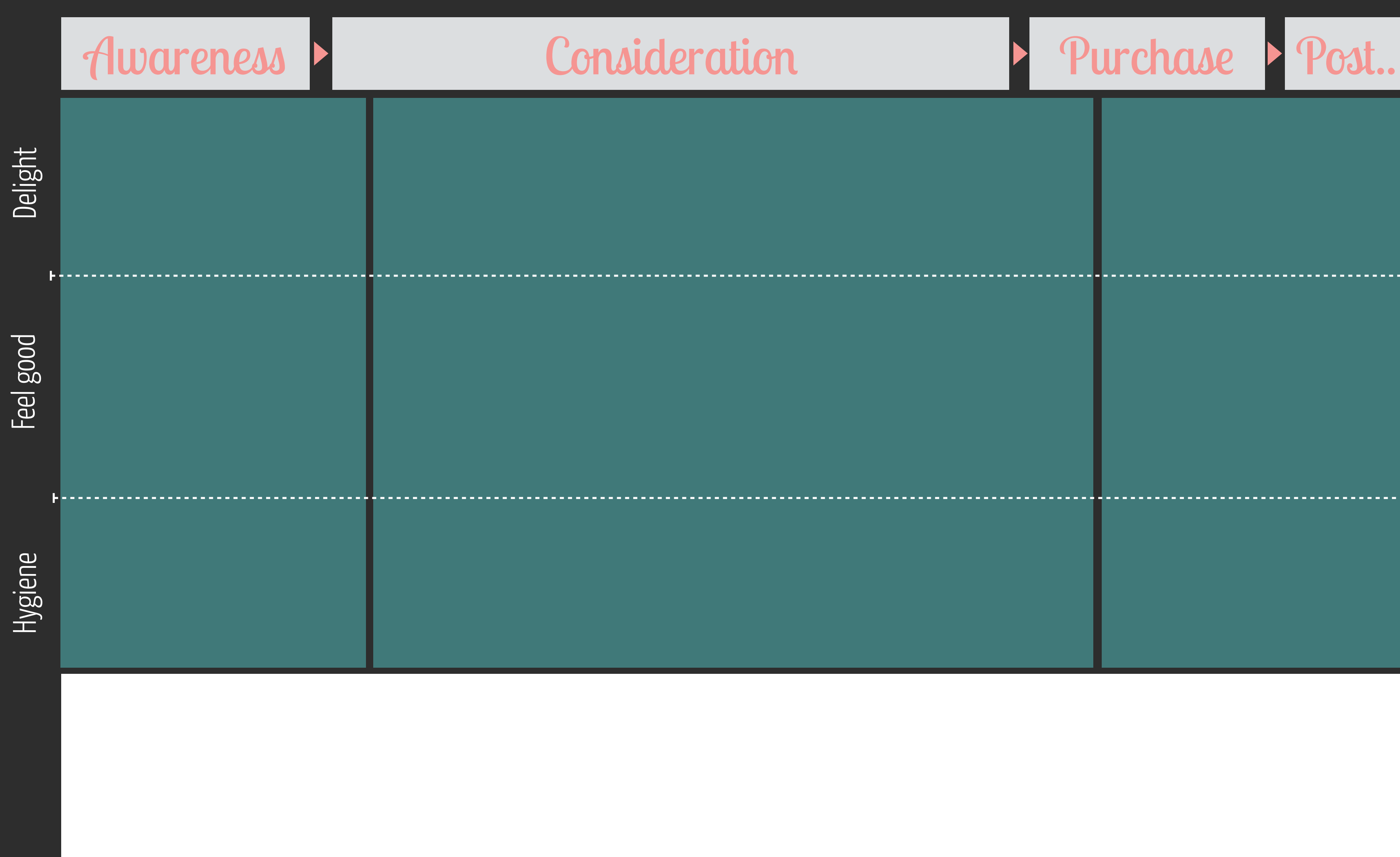

It knows me & what I want

Map out experience goals

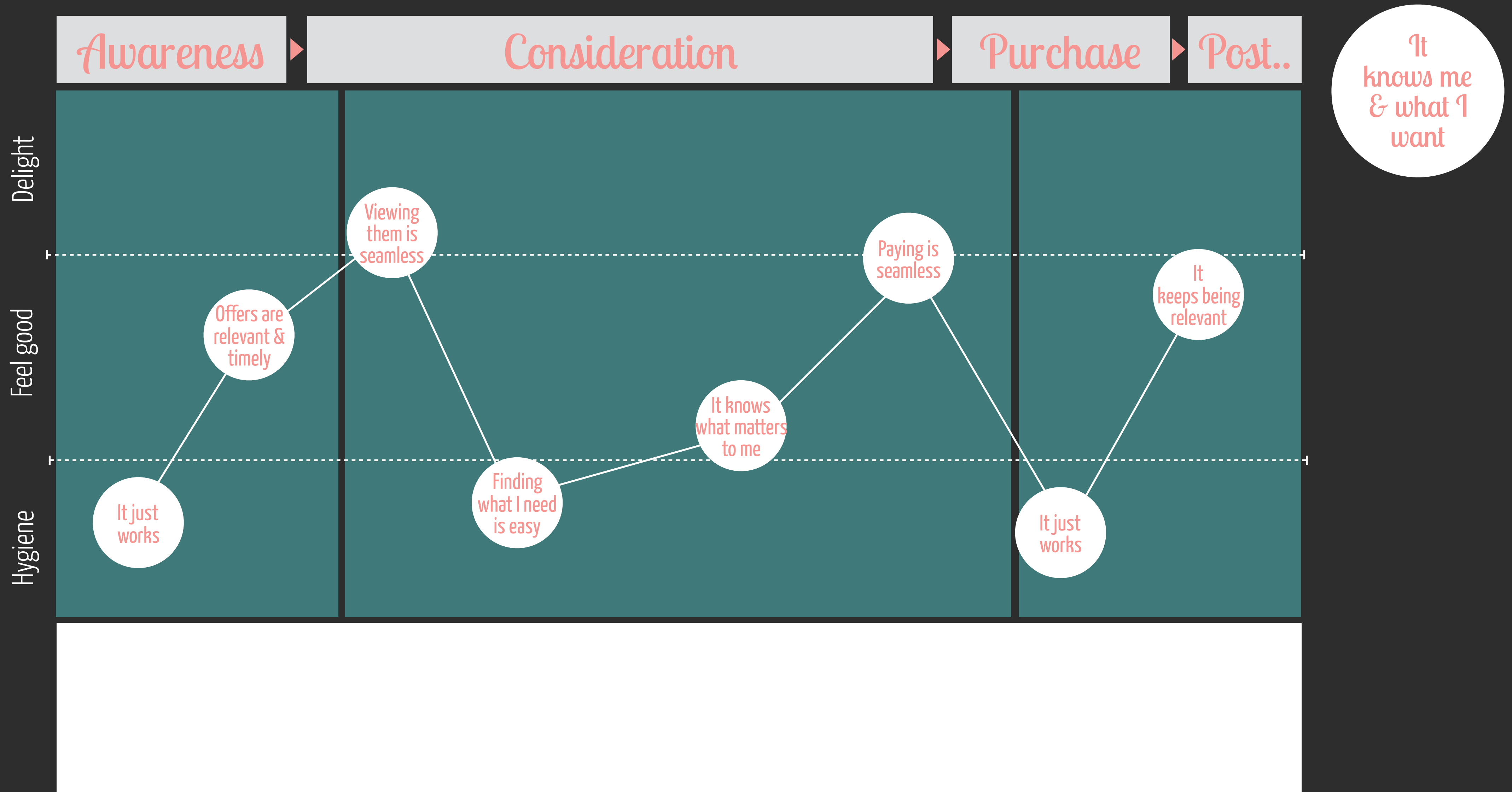

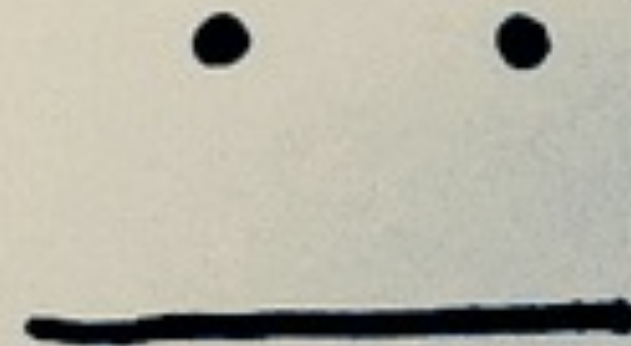
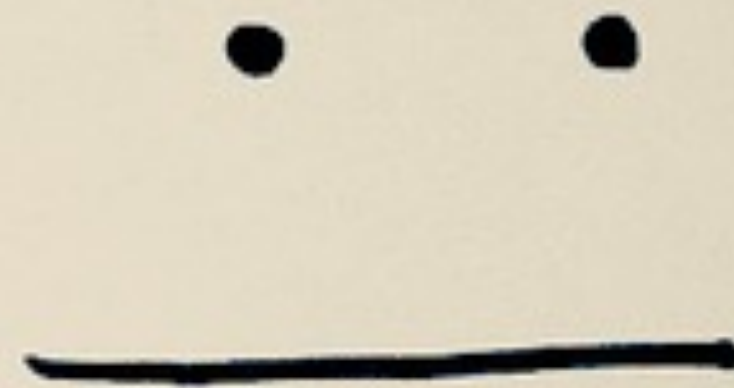
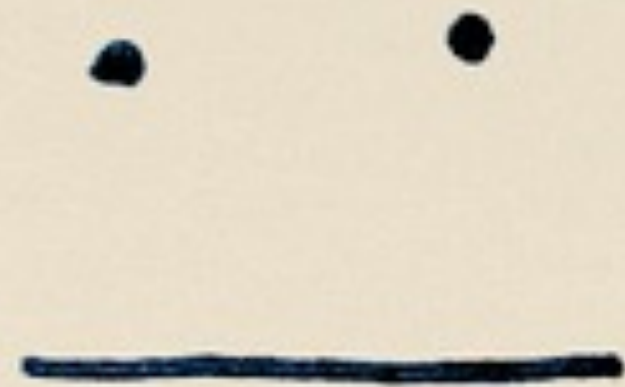

Ensure there is
a good balance

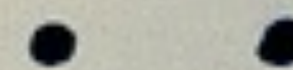
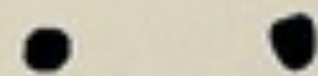
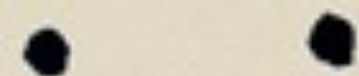
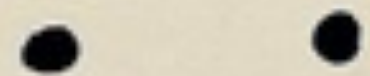
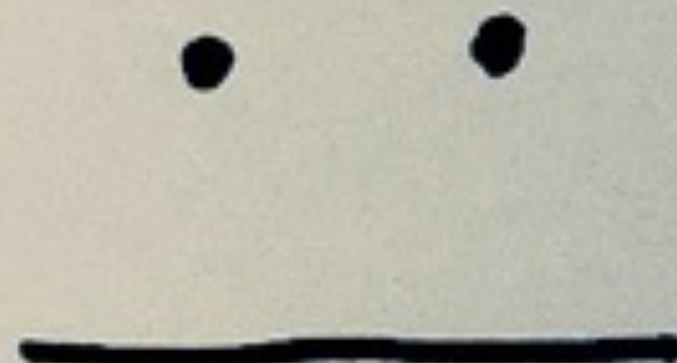
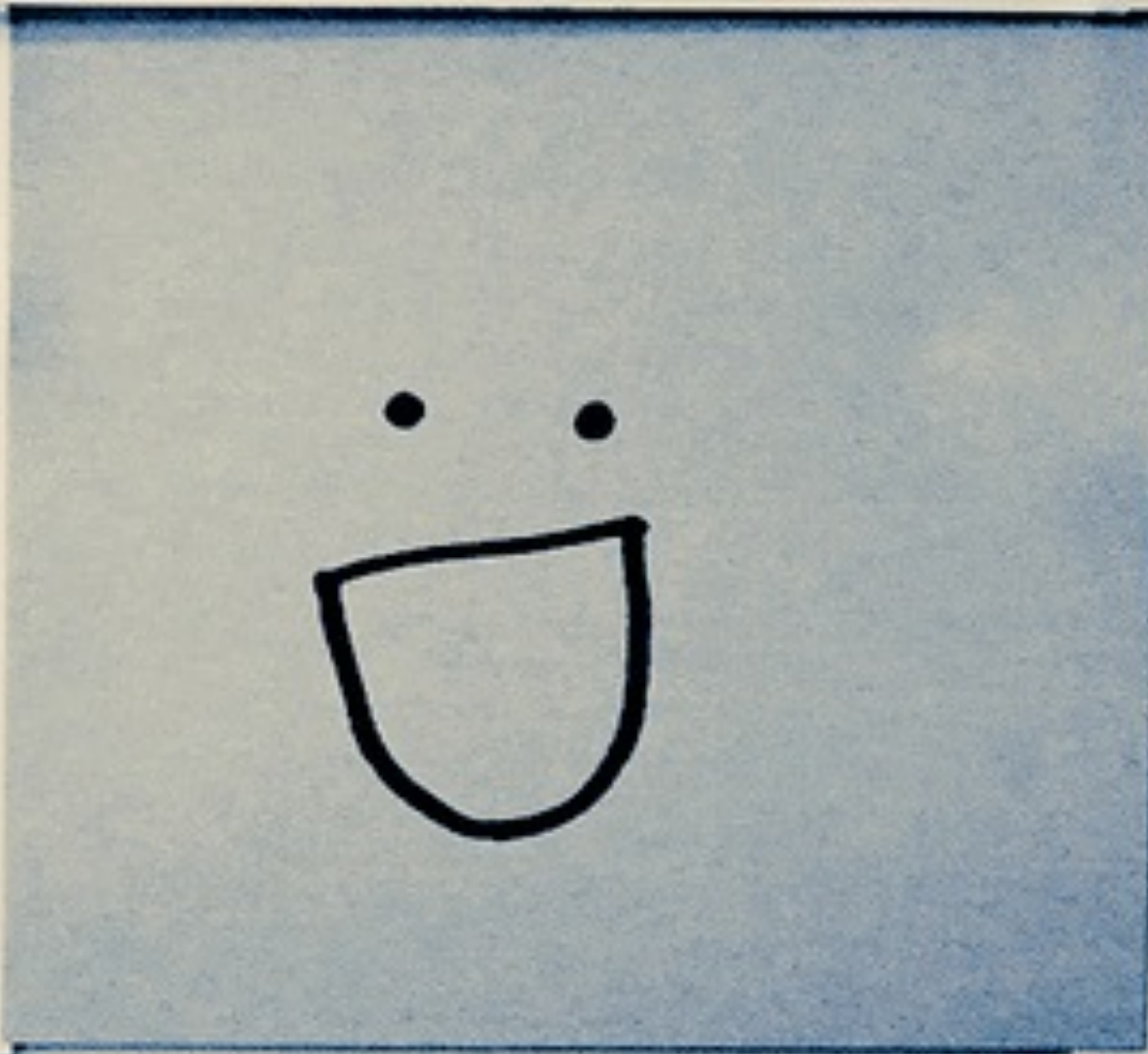

...avoid ending up with this

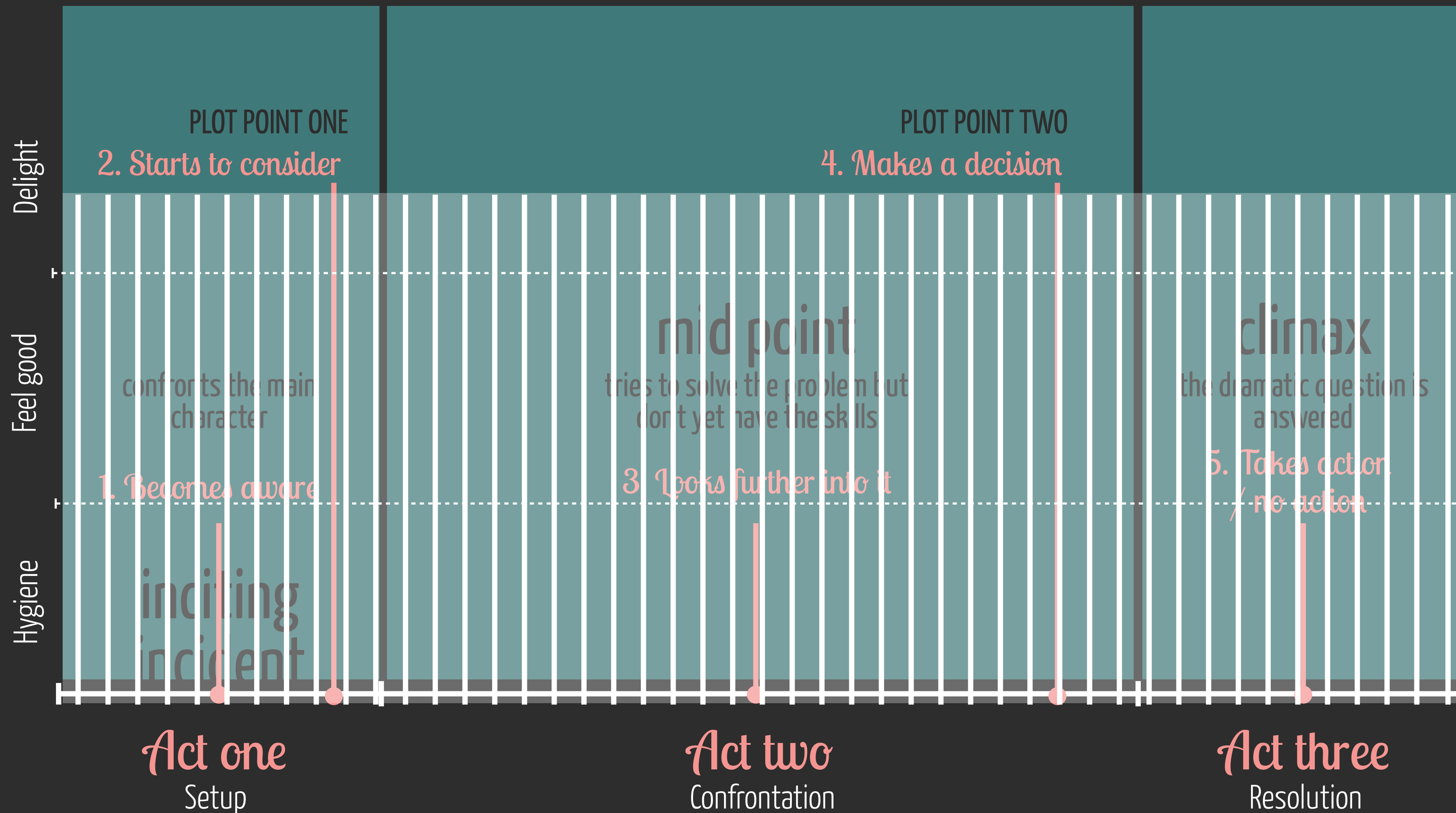



We cannot be at
the top all the time

More realistic

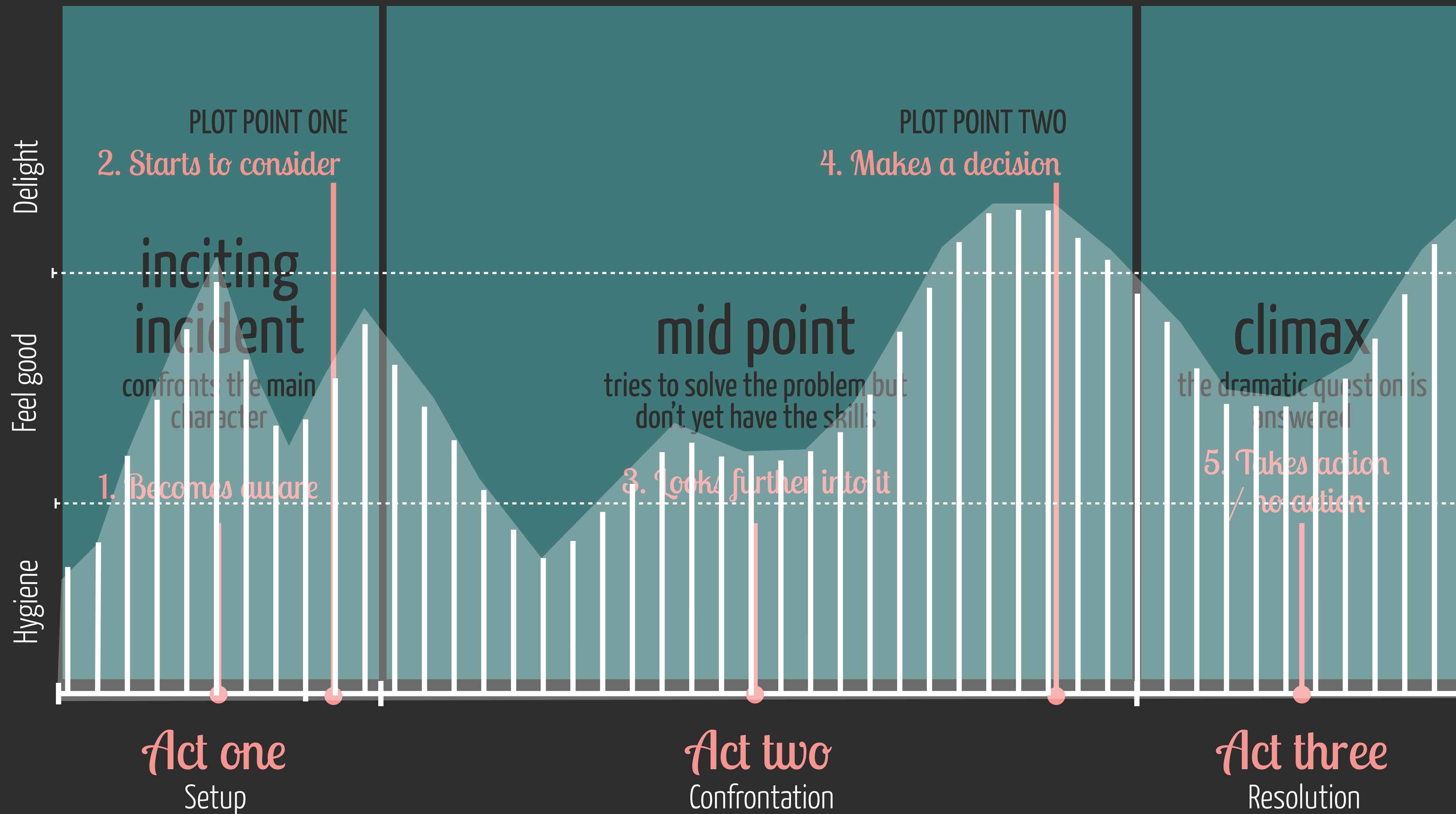

1. Define device roles & hand-off points
2. Design systems of components
3. Consider notifications part of the interface
4. Consider the wider context
5. Cater for different input methods
6. Embrace the chaos
7. Design for the individual
8. Content + Context is king
9. Timing is everything
10. Work with experience goals

Map out experience goals

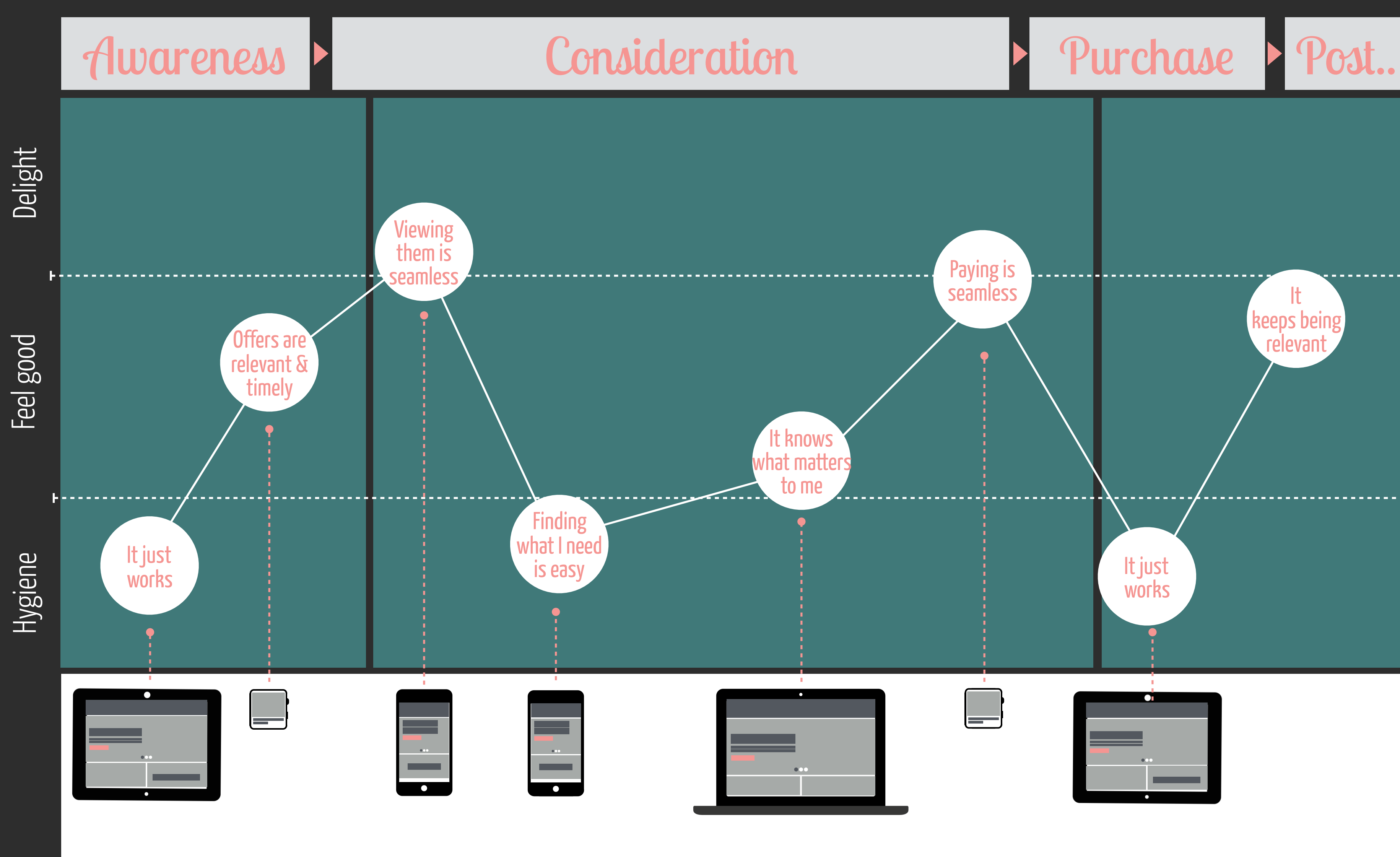

It knows me & what I want



Whatever we create & whoever it is for,
we want people to do something



What do we want our users to see?
What is the story we want to tell?

Where do we want to take them?

“ We’re not just making pretty interfaces.
We’re actually in the process of making an
environment where we’ll spend most of
our time, for the rest of our lives.
We’re the designers. We’re the builders.
What do we want that environment to
feel like? What do we want to feel like. ”

- Wilson Minor





It all start with
Once upon a time...

Or maybe

Once upon a design...

The background features a dark, moody image of an open book. From the center of the book, a plant with two large, rounded, dark leaves grows upwards. The overall color palette is dark, with shades of brown, black, and a hint of red from the text.

Thank you. Questions?

.....

@annadahlstrom

www.annadahlstrom.com